

PE-50配色表 / COLOR CODE

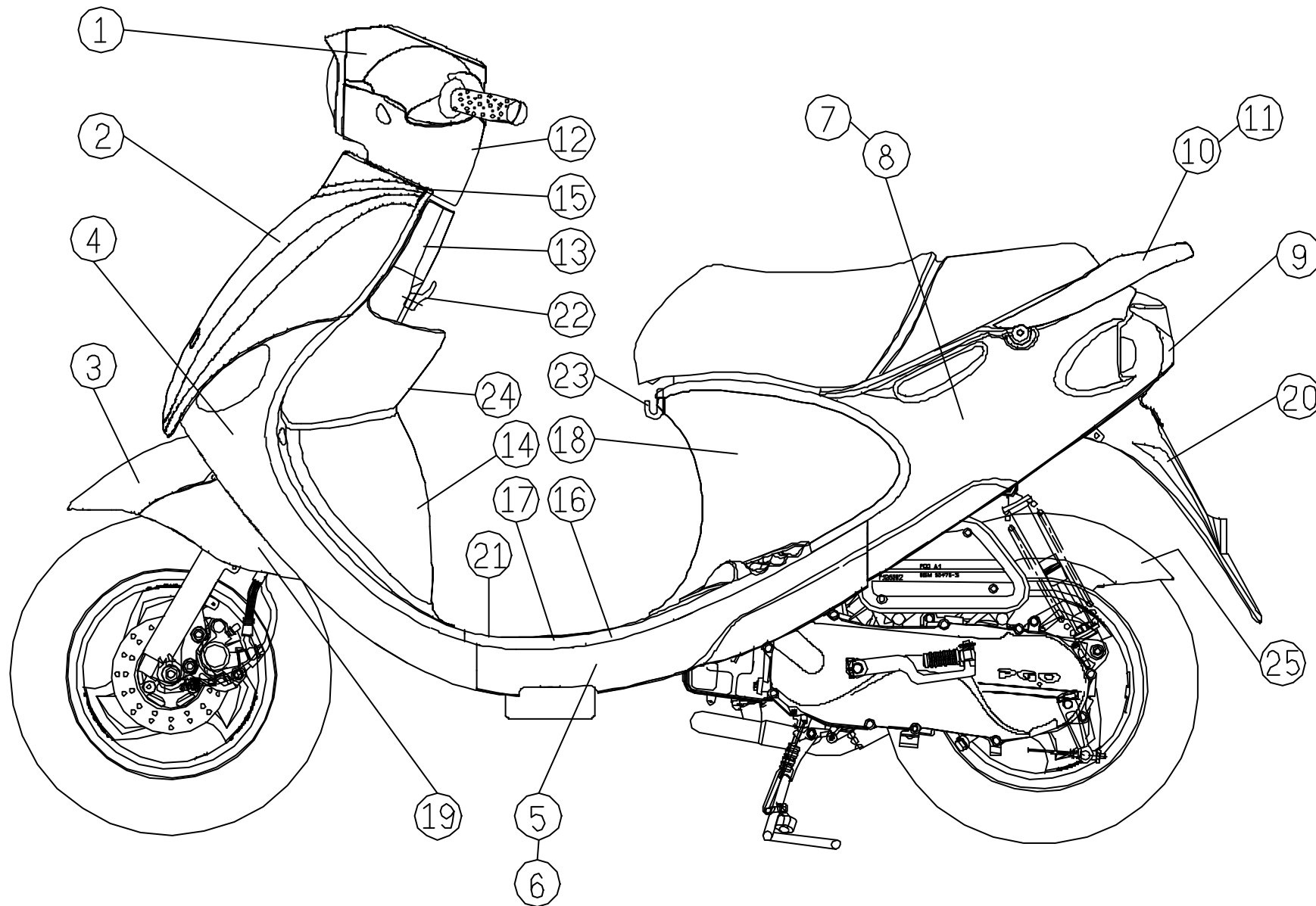

E1

曲軸箱機油泵
CRANKCASE OIL PUMP

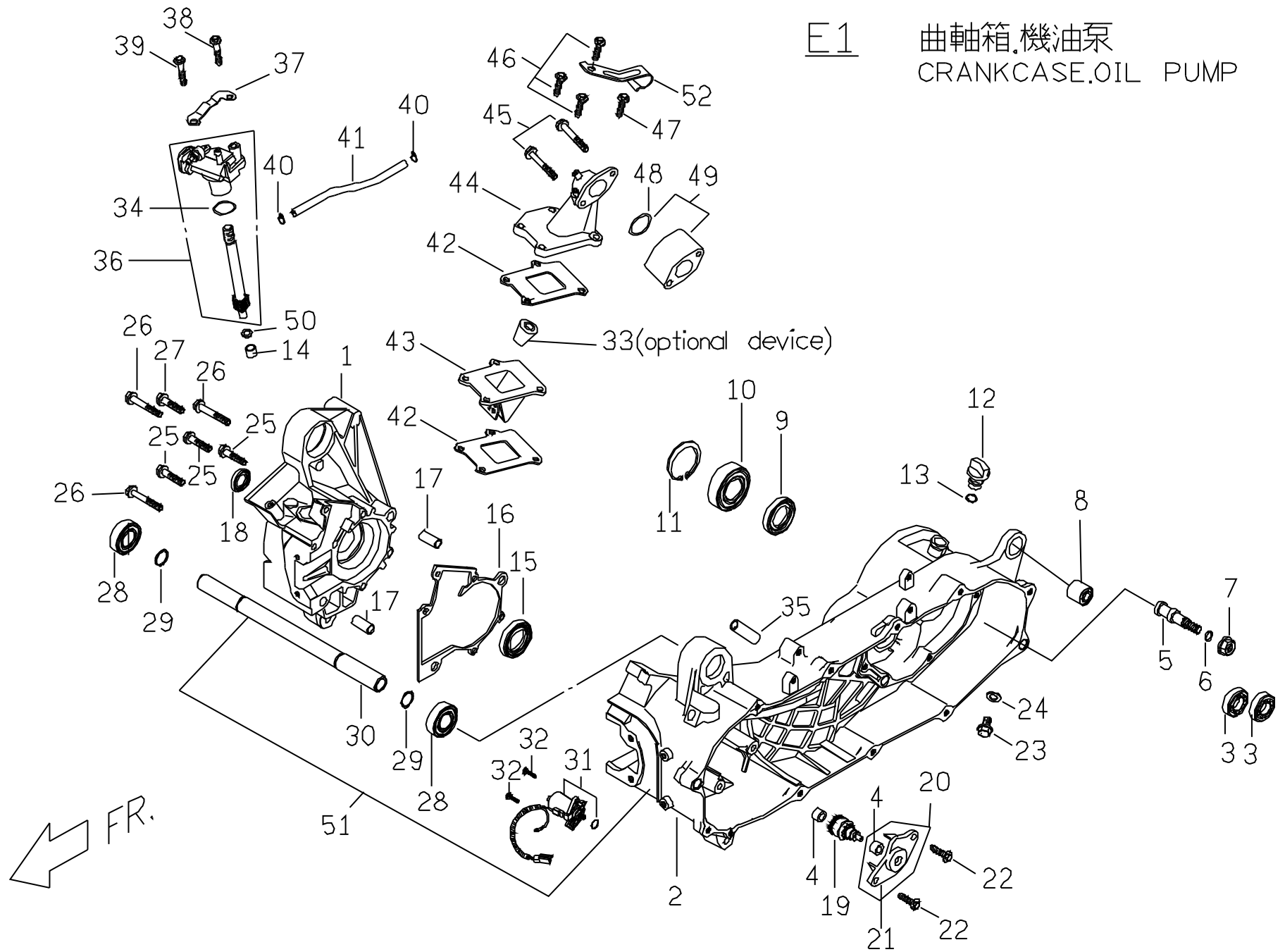

E1 CRANKCASE / 曲軸箱・機油泵

No.	Part No.	Q'TY	PART NAME	PART NAME	REMARK
項目	零件號碼	數量	零件中文名稱	零件英文名稱	備註
27	90190602700	1	六角凸緣螺栓	HEXAGON FLANGE BOLT	
28	96530600300	2	雙封深槽滾珠軸承(6003)	BALL BEARING DOUBLE SEALED	
29	92171700000	2	C形扣環	RETAINING RING C TYPE	
30	P5486020000	1	引擎吊架樞軸	ENGINE HANGER SHAFT	
31	E1241001000	1	起動馬達組合	MOTOR COMP., STARTER	
32	90210602000	2	六角承窩螺栓	HEXAGON FLANGE BOLT	
34	95512000001	1	O形環	O RING	
36	P10810010001	1	機油泵總成	OIL PUMP ASSY.	
37	P10812100000	1	機油泵壓板	OIL PUMP PLATE	
38	90190603500	1	六角凸緣螺栓	HEXAGON FLANGE BOLT	
39	90190601203	1	六角凸緣螺栓	HEXAGON FLANGE BOLT	
40	93550500800	2	管束	SPRING PIN	
41	P5081301000	1	機油輸送管(OUT)	RUBBER TUBE	
42	P1261020000	2	簧片閥襯墊	GASKET, REED VALVE	
43	P1261101000	1	簧片閥組合	REED VALVE COMP.	
44	P5261011000	1	進氣歧管	INTAKE MANIFOLD	
45	90190604500	2	六角凸緣螺栓(M6*45)	HEXAGON FLANGE BOLT	
46	90180602500	4	六角凸緣螺栓	HEXAGON FLANGE BOLT	
48	95512300000	1	O形環	O RING	
49	P5261300000	1	化油器絕緣板組合	INSULATOR, ASSY., CARB.	
50	92140700001	1	耐磨墊圈	PLAIN WASHER	
51	P1706400000	1	導線夾子	FIXING CLIP	
52	P506K0100001	1	左右曲軸箱組合	R/L CRANKCASE COMP.	W/O SAI SYSTEM

E1 CRANKCASE / 曲軸箱・機油泵

No.	Part No.	Q'TY	PART NAME	PART NAME	REMARK
項目	零件號碼	數量	零件中文名稱	零件英文名稱	備註
1	P5061010000	1	右曲軸箱	RH. CRANKCASE	
2	P50620100001	1	左曲軸箱	LH. CRANKCASE	W/O SAI SYSTEM
3	96510620000	2	滾珠軸承(6200)	BALL BEARING	
4	E1062130000	2	襯套	BUSH	NOT SUPPLIED
5	P1407430000	1	後煞車蹄樞軸	PIVOT,RR. BRAKE SHOE	
6	95510800000	1	O形環(7.5*1.5)	O RING	
7	92040800000	1	六角凸緣螺帽(M8)	HEXAGON FLANGE NUT	
8	P1062020000	1	防震襯套	RUBBER BUSH	
9	95572540700	1	TC形油封(D40*D24.5*7)	OIL SEAL TC TYPE	
10	96530620400	1	雙封滾珠軸承(6204)	BALL BEARING DOUBLE SEALED	
11	92164700000	1	C形扣環	RETAINING RING C TYPE	
12	P1062150000	1	機油螺栓	OIL BOLT	
13	95511400000	1	O形環	O RING	
14	E1061030000	1	機油泵襯套	OIL PUMP BUSH	
15	95572038700	1	TC形油封(D38*D19*7)	OIL SEAL TC TYPE	
16	P1061040000	1	曲軸箱墊片	CRANKCASE GASKET	
17	93541002300	2	定位銷	LOCK PIN	
18	95571525700	1	TC形油封(D15*D25.5*7)	OIL SEAL TC TYPE	
19	E1242000000	1	起動馬達惰齒輪組合	IDLE GEAR COMP., STARTER	
20	P1242111000	1	起動離合器固定板組合	FIXED PLATE STARTER COMP.	
21	NA	1	固定板	FIXING PLATE	NOT SUPPLIED
22	90180602000	2	六角凸緣螺栓	HEXAGON FLANGE BOLT	
23	90190801200	1	六角凸緣螺栓	HEXAGON FLANGE BOLT	
24	92140800001	1	平墊圈	WASHER	
25	90190604500	3	六角凸緣螺栓	HEXAGON FLANGE BOLT	
26	90190606000	3	六角凸緣螺栓	HEXAGON FLANGE BOLT	

E2. FAN COVER.COOLING COWL
CYLINDER,CYLINDER HEAD

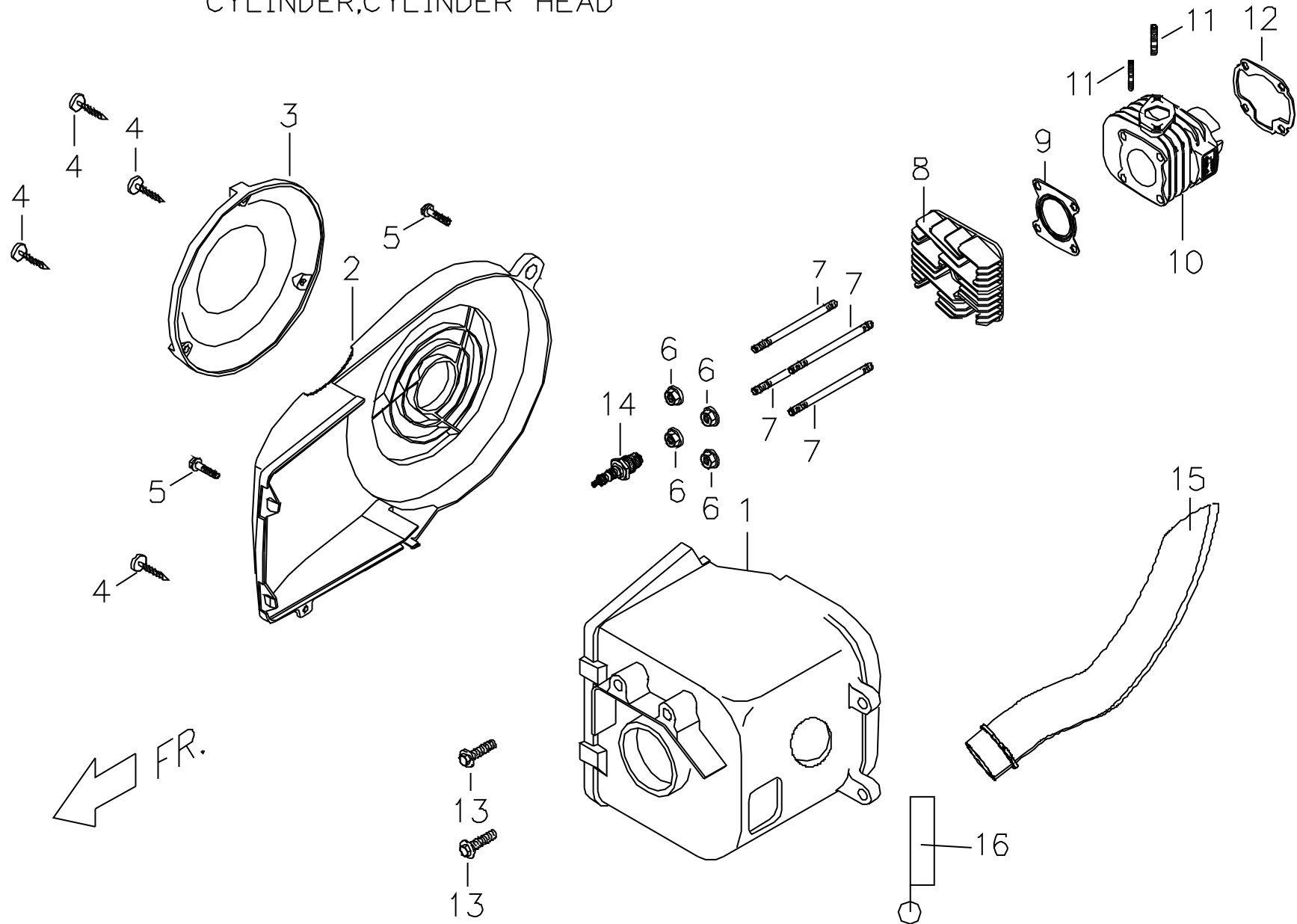

E2 CYLINDER / 風扇罩・冷卻罩・汽缸・汽缸蓋

No.	Part No.	Q'TY	PART NAME	PART NAME	REMARK
項目	零件號碼	數量	零件中文名稱	零件英文名稱	備註
1	P1042102000	1	冷卻罩	COOLING COWL	NFI
2	P1042001000	1	風扇罩	FAN COVER	
3	E1042200000	1	風扇罩蓋	FAN COVER	
4	90110401200	4	十字槽盤頭自攻螺釘 (M4*16L)	CR PAN HD. TAPPING SCREW	
5	90180602000	2	六角凸緣螺栓	HEXAGON FLANGE BOLT	
6	92040700000	4	六角凸緣螺帽	HEXAGON FLANGE NUT	
7	P1061050000	4	雙頭螺栓	STUD BOLT	
8	P5065010000	1	汽缸蓋	CYLINDER HEAD	
9	P1065110000	1	汽缸蓋襯墊	GASKET, CYLINDER HEAD	
10	P1064010000	1	汽缸	CYLINDER	
11	90170602602	2	雙頭螺栓	STUD BOLT	
12	P1064110000	1	汽缸襯墊	CYLINDER GASKET	
13	90190601201	2	六角凸緣螺栓	HEXAGON FLANGE BOLT	
14	P12220000002	1	火星塞 (NGK BPR7HS)	IGNITION PLUG	
15	P5042270000	1	熱導風管	AIR PIPE	
16	P5706040000	1	後剎車導線固定勾	RR BRAKE TAKER	

E3 風扇.發電機
FAN,GENERATOR

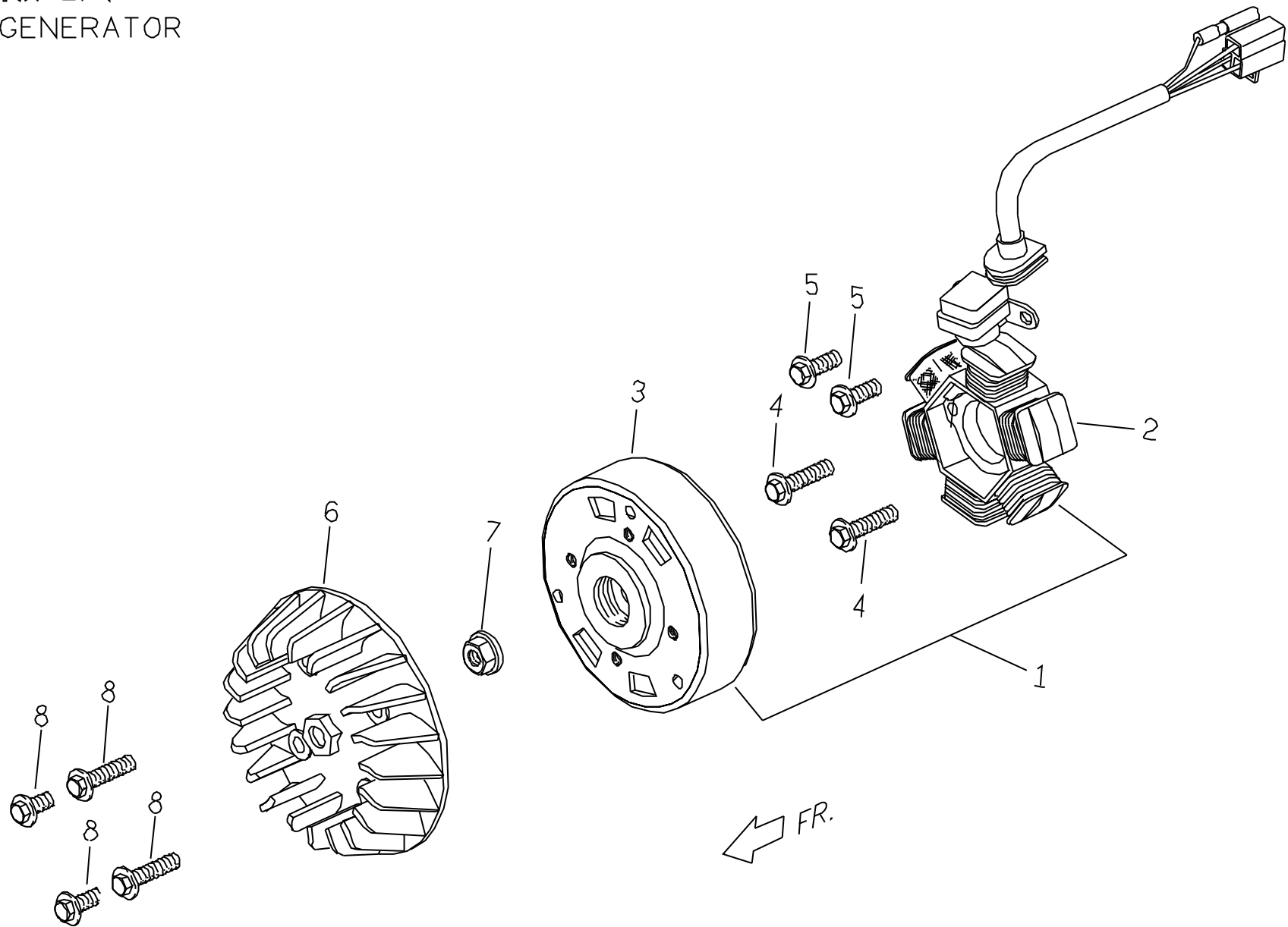

E3 GENERATOR / 風扇・發電機

No.	Part No.	Q'TY	PART NAME	PART NAME	REMARK
項目	零件號碼	數量	零件中文名稱	零件英文名稱	備 註
1	P1221000002	1	交流磁電機總成	AC GENERATOR ASSY.	
2	P1221020002	1	固定子組合	FLYWHEEL COMP.	
3	P1221010002	1	飛輪組合	STATOR COMP.	
4	90180601800	2	六角凸緣螺栓 (M6*20L)	HEXAGON FLANGE BOLT	
5	90190601203	2	六角凸緣螺栓	HEXAGON FLANGE BOLT	
6	P1043000000	1	風扇	FAN	
7	92041000001	1	六角凸緣螺帽	HEXAGON FLANGE NUT	
8	90190601204	4	六角凸緣螺栓	HEXAGON FLANGE BOLT	

E4 DRIVING FACE

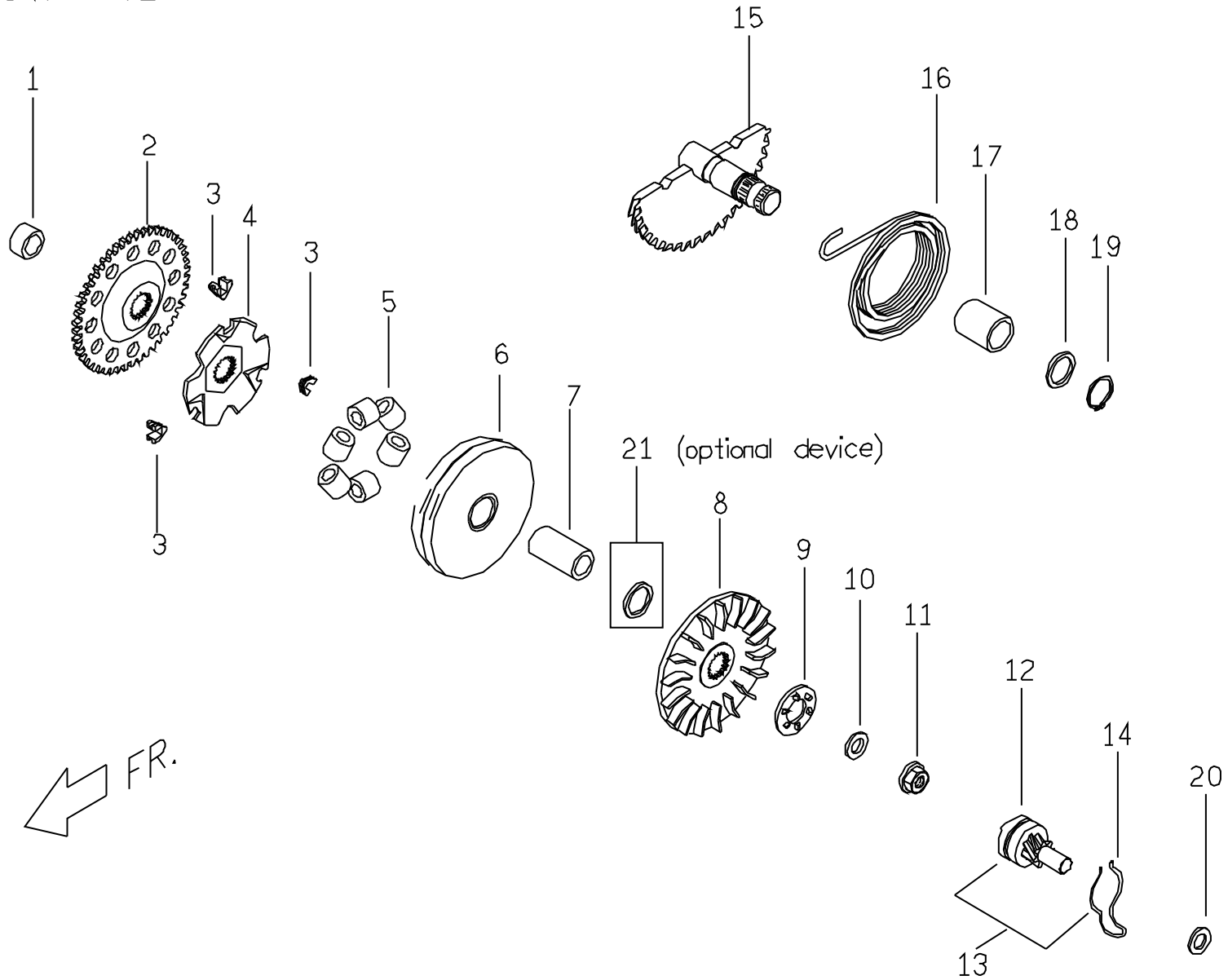

E4 DRIVING PULLEY / 驅動面皮帶輪

No.	Part No.	Q'TY	PART NAME	PART NAME	REMARK
項目	零件號碼	數量	零件中文名稱	零件英文名稱	備註
1	P5242210000	1	間隔套管	SPACER	
2	P1242200000	1	起動被動齒輪	DRIVEN GEAR, STARTER	
3	P1121320000	3	滑件	SLIDE PIECE	
4	P1121310000	1	斜坡板	RAMP PLATE	
5	P5121200000	6	配重滾子組合	WEIGHT ROLLER COMP. (9.5G)	
6	P1121101000	1	活動驅動面組合	DRIVING FACE COMP., MOVABLE	
7	P5121050000	1	活動驅動面輪殼	BOSS, MOVABLE DRIVE FACE	
8	P1121060000	1	驅動面	DRIVE FACE	
9	P1251030000	1	起動棘輪	RATCHET KICK STARTER	
10	92141000001	1	平墊圈 (10*2T)	PLAIN WASHER	
11	92041000001	1	六角凸緣螺帽	HEXAGON FLANGE NUT	
12	E1251010000	1	腳踏起動被動齒輪組合	DRIVEN GEAR COMP., KICK STARTER	NOT SUPPLIED
13	E1251000000	1	腳踏被動齒輪彈簧組合	DRIVEN GEAR & SPRING COMP.	
14	E1251020000	1	起動齒輪磨擦彈簧	SPRING, FRICTION STARTER GEAR	NOT SUPPLIED
15	E1251101000	1	腳踏起動心軸組合	SPINDLE COMP., KICK STARTER	
16	E2251110000	1	扭轉彈簧	TORSION SPRING	
17	E1251120000	1	襯套 (踏桿)	BUSH	
18	92141400000	1	平墊圈	PLAIN WASHER	
19	92171400000	1	C形扣環	RETAINING RING C TYPE	
20	92141000011	1	平墊圈	PLAIN WASHER	

E5

曲柄軸, 活塞
CRANKSHAFT, PISTON

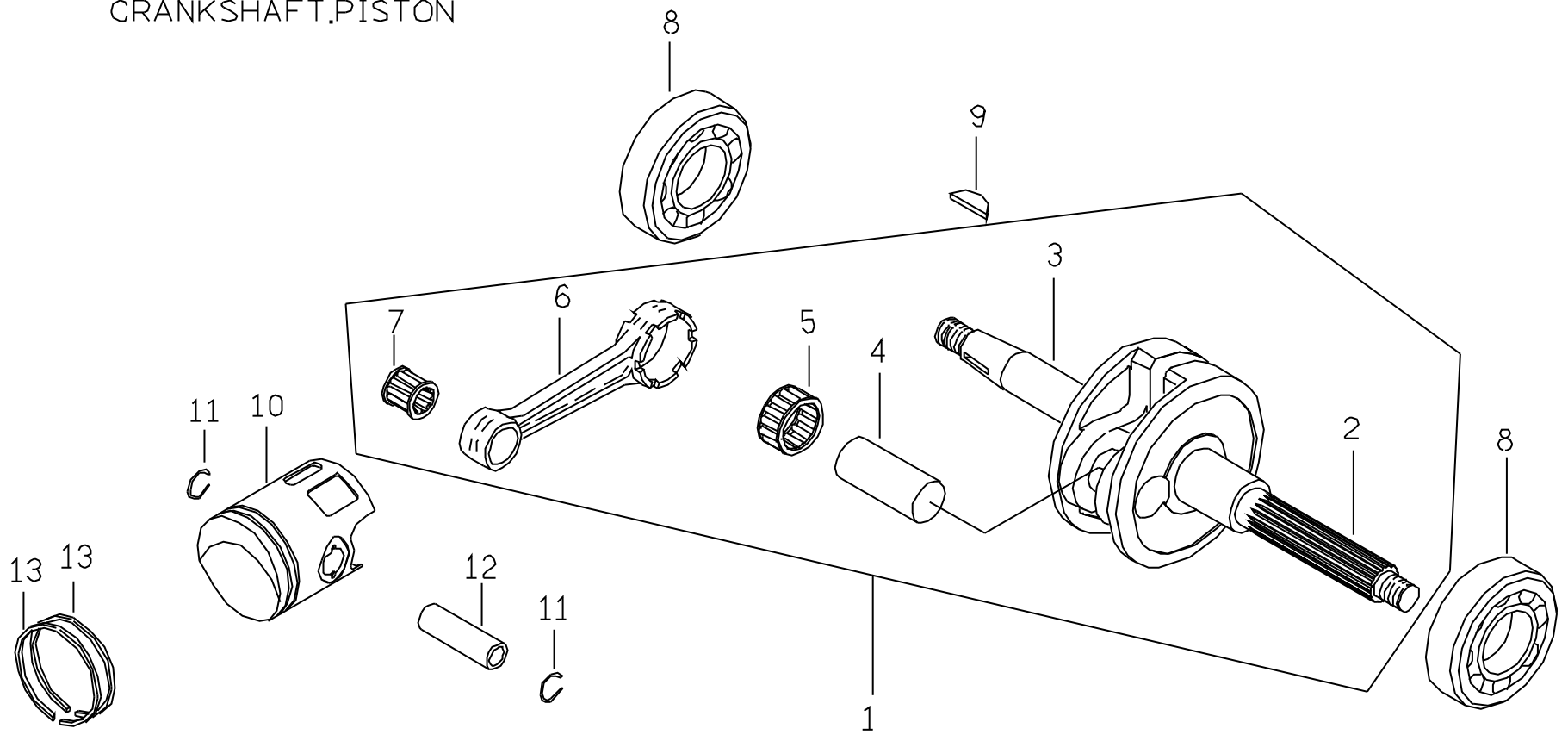

← FR.

E5 CRANKSHAFT / 曲柄軸・活塞

No.	Part No.	Q'TY	PART NAME	PART NAME	REMARK
項目	零件號碼	數量	零件中文名稱	零件英文名稱	備註
1	P1066000000	1	曲柄軸組合	CRANKSHAFT COMP.	
2	NA	1	左曲柄軸	LH., CRANKSHAFT	NOT SUPPLIED
3	NA	1	右曲柄軸	RH., CRANKSHAFT	NOT SUPPLIED
4	P1066030000	1	曲軸銷	CRANK PIN	
5	96590162200	1	籠式滾針軸承	BEARING CAGE	
6	P1066120000	1	連桿	CONNECTING ROD	
7	96600101400	1	籠式滾針軸承	BEARING CAGE	
8	E1062100000	2	滾珠軸承 (SC04A50)	BALL BEARING	
9	93530302400	1	半圓鍵	WOODEUFF KEY	
10	P5067010000	1	活塞	PISTON	
11	E1067150000	2	活塞銷夾	CLIP, PISTON PIN	
12	P1067110000	1	活塞銷	PISTON PIN	
13	E10673100001	2	活塞環	PISTON RING	

E6 被驅動面皮帶輪組合
BELT PULLEY COMP., DRIVEN FACE

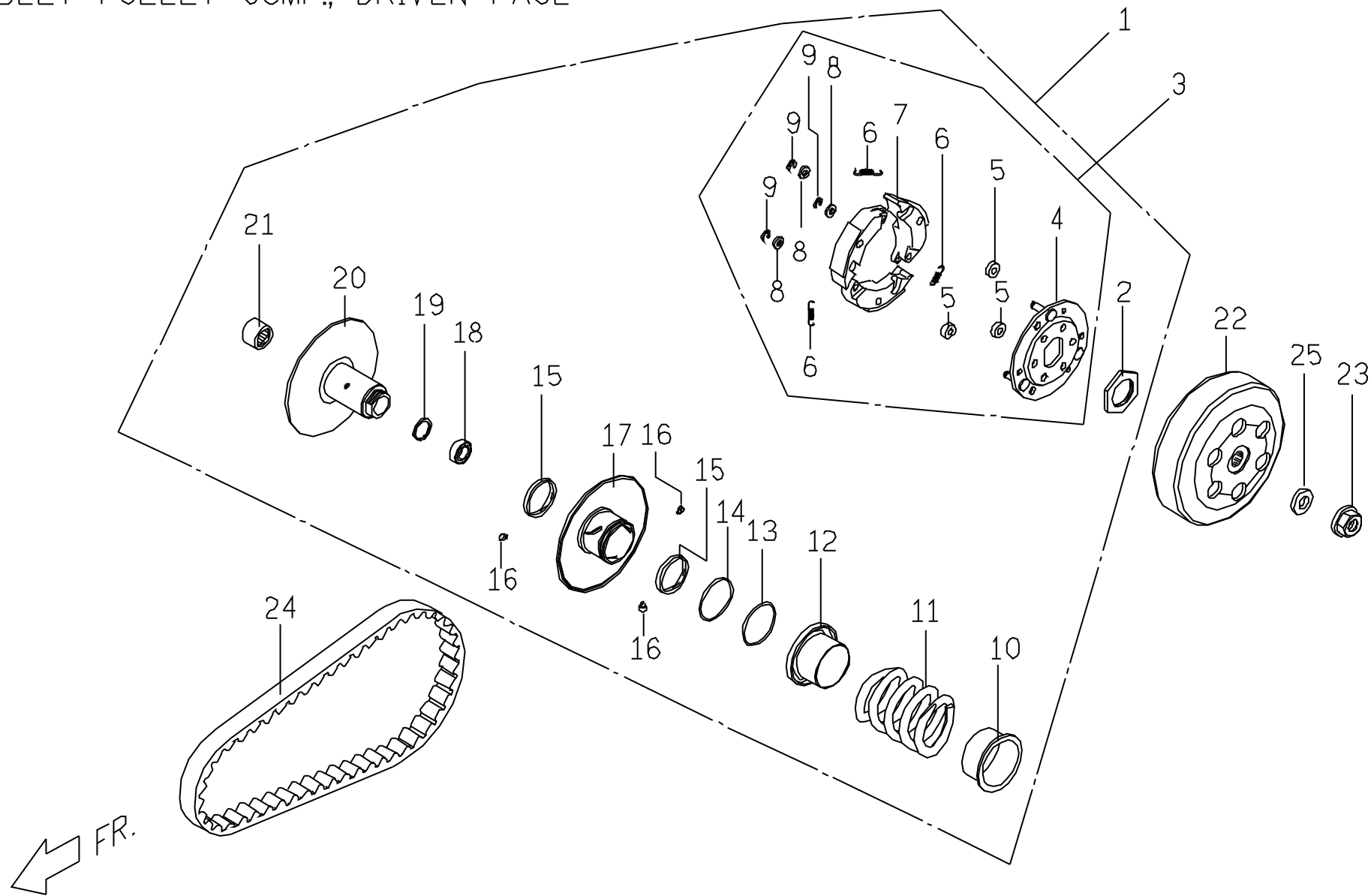

E6 DRIVEN PULLEY / 被驅動面皮帶輪組合

No.	Part No.	Q'TY	PART NAME	PART NAME	REMARK
項目	零件號碼	數量	零件中文名稱	零件英文名稱	備註
1	P1123701000	1	被驅動面皮帶輪組合	BELT PULLEY COMP., DRIVEN FACE	
2	P1123410000	1	特殊螺帽	NUT	
3	P1123600000	1	驅動板組合	DRIVE PLATE COMP	
4	P1123300000	1	驅動板本體組合	BODY COMP., DRIVE PLATE	
5	P1123420000	3	離合器阻尼橡膠	DAMPER RUBBER, CLUTCH	
6	P1123430000	3	離合器彈簧	SPRING, CLUTCH	
7	P1123441000	3	離合器比重塊	CLUTCH LINING	
8	92140600008	3	平墊圈	PLAIN WASHER	
9	92180500000	3	E型扣環	RETAINING RING E TYPE	
10	P1123330000	1	彈簧套筒	COLLAR SPRING	
11	P1123520000	1	被驅動面彈簧	SPRING, DRIVEN FACE	
12	P1123530000	1	密封套筒	SEALED SOCKET	
13	95513600000	1	O形環	O RING	
14	95514000001	1	O形環	O RING	
15	95593439300	2	G型油封	OIL SEAL G TYPE	
16	P1123240000	3	導滾銷	PIN, GUIDE ROLLER	
17	P1123210000	1	活動被驅動面本體組合	BODT COMP., MOVABLE DRIVEN FACE	
18	96520690100	1	單封深槽滾珠軸承 (24*12*6)	DEEP GROOVE BALL BEAR ONE SEAL	
19	92162400000	1	C形扣環	RETAINING RING C TYPE	
20	P1123110000	1	被驅動面本體組合	BODY COMP., DRIVEN FACE	
21	E1123140000	1	滾針軸承	NEEDLE BEARING	
22	P1123510000	1	離合器外套本體組合	OUTER BODY COMP., CLUTCH	
23	92041000001	1	六角凸緣螺帽	HEXAGON FLANGE NUT	
24	NE122000000	1	皮帶	BELT	
25	92141000001	1	平墊圈	PLAIN WASHER	

E7 左邊蓋
LH. SIDE COVER

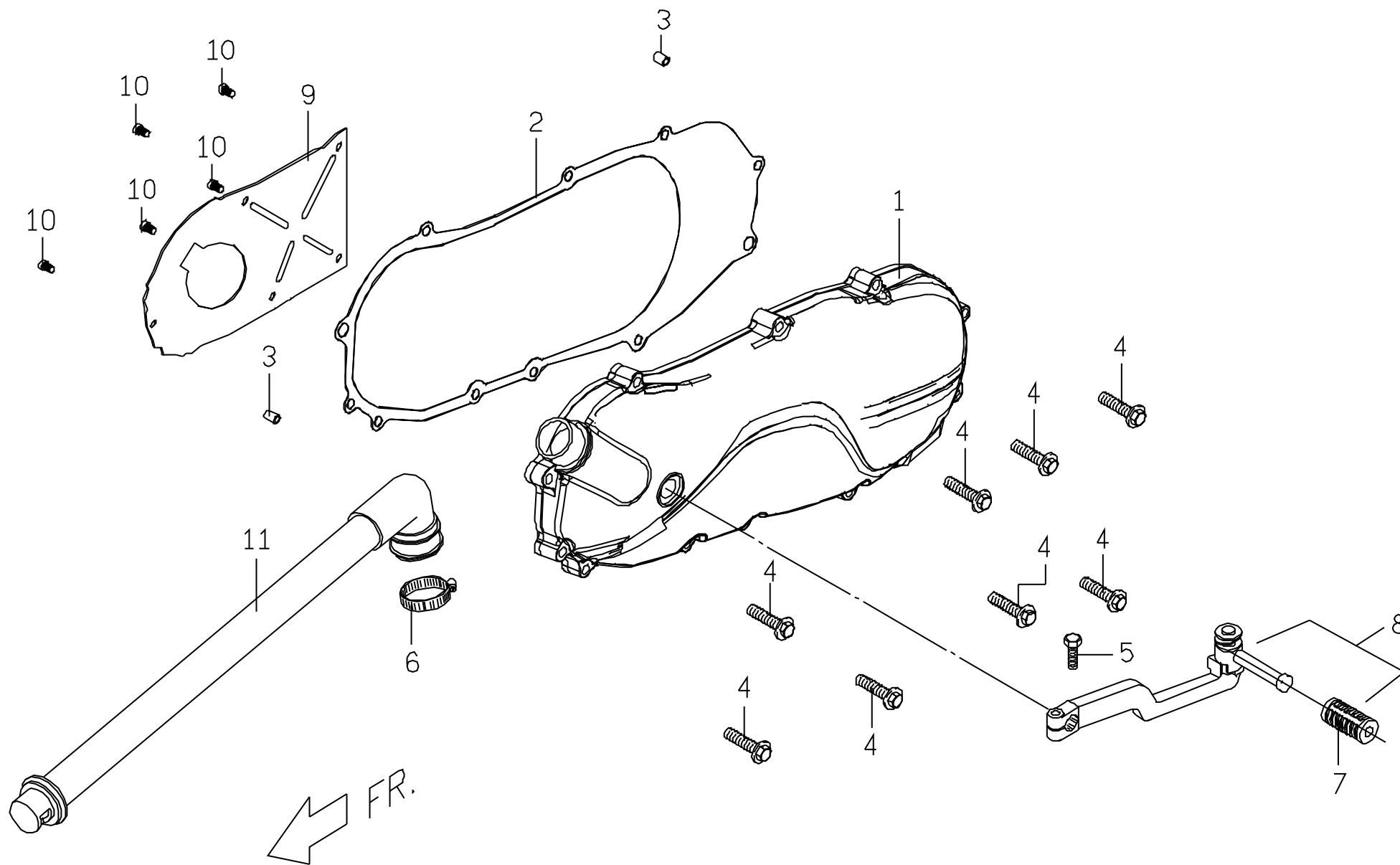

E7 LEFT CASE / 左邊蓋

No.	Part No.	Q'TY	PART NAME	PART NAME	REMARK
項目	零件號碼	數量	零件中文名稱	零件英文名稱	備註
1	P5063010720	1	左邊蓋 (散銀)	LH., SIDE COVER	
2	P5063020000	1	左邊蓋襯墊	GASKET, LH. SIDE COVER	
3	93541001401	2	定位銷 (10*14)	LOCK PIN	
4	90190603502	8	六角凸緣螺栓 (M6*35L)	HEXAGON FLANGE BOLT	
5	90020602202	1	六角頭螺栓	HEXAGON HEAD BOLT	
6	E1706280000	1	軟管夾 (MIN30-MAX40)	HOSE CLAMP	
7	E1251240000	1	起動板膠套	RUBBER PAD, KICK STARTER	
8	P1251200000	1	起動踏桿組合	ARM COMP., KICK STARTER	
9	P1063060000	1	隔板	PARTITION PLATE	
10	90050500900	5	十字槽圓頭機器螺釘	CR ROUND HD. MACHINE SCREW	
11	P5063030000	1	通風膠管	BREATHER PIPE	

E8 傳動系
TRANSMISSION

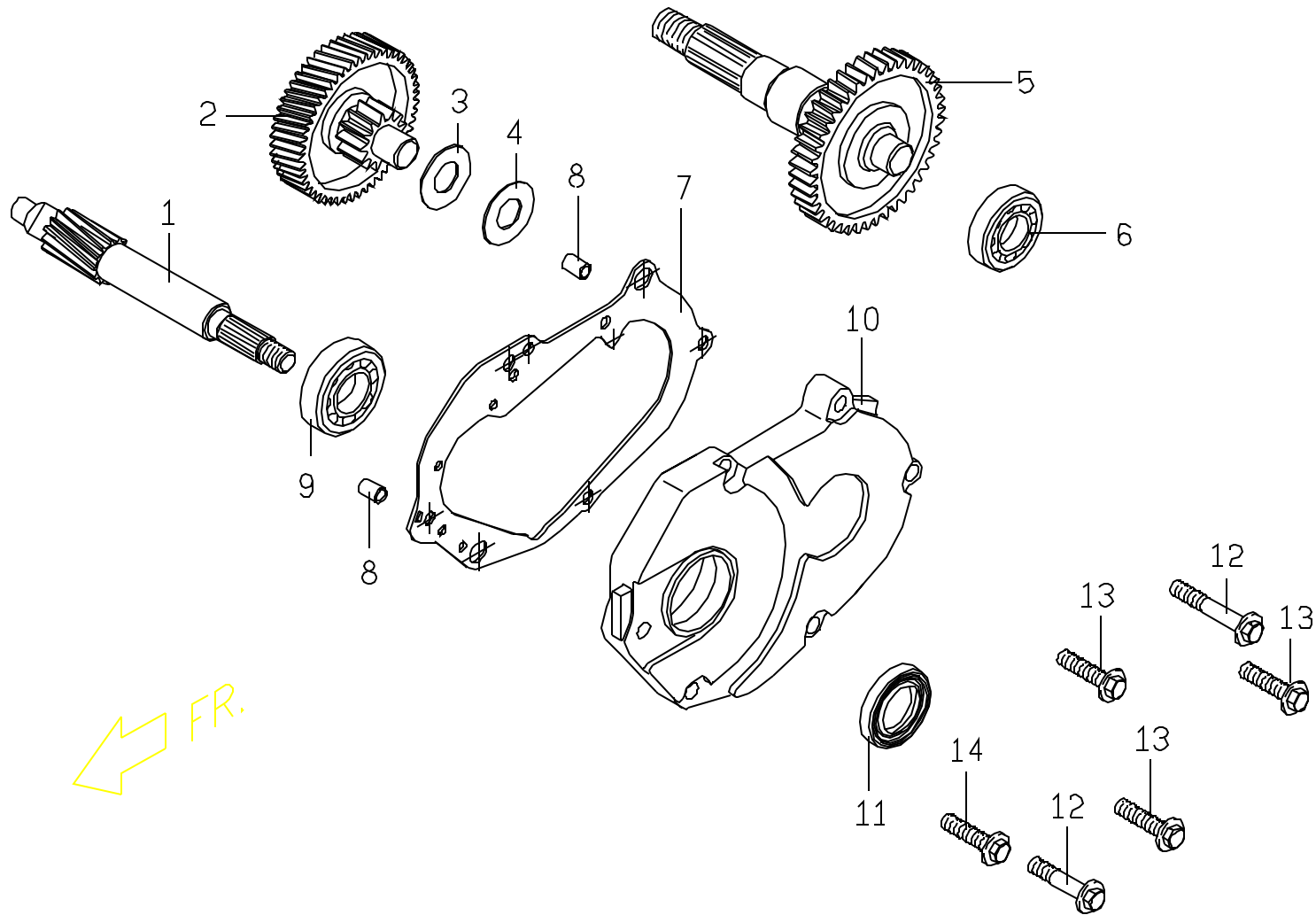

E8 TRANSMISSION / 傳動系

No.	Part No.	Q'TY	PART NAME	PART NAME	REMARK
項目	零件號碼	數量	零件中文名稱	零件英文名稱	備註
1	P5141100000	1	驅動軸	DRIVE SHAFT	
2	P5141200000	1	惰齒輪組合	IDLE GEAR COMP.	
3	P1141230000	1	盤形彈簧墊圈	DISC SPRING WASHER	
4	92141400003	1	平墊圈 (14D*1T)	PLAIN WASHER	
5	P5141300000	1	最終齒輪組合	FINAL GEAR COMP.	
6	96510620200	1	滾珠軸承 (6202)	BALL BEARING	
7	P1141020000	1	傳動箱蓋襯墊	TRANSMISSION COVER GASKET	
8	93541001401	2	定位銷 (10*14)	LOCK PIN	
9	96510620301	1	滾珠軸承 (6203)	BALL BEARING	
10	P1141010000	1	傳動箱蓋	TRANSMISSION COVER	
11	95571735700	1	TC型油封 (D35*D16.4*7)	OIL SEAL TC TYPE	
12	90190603500	2	六角凸緣螺栓 (M6*35L)	HEXAGON FLANGE BOLT	
13	90180602500	3	六角凸緣螺栓 (M6*25L)	HEXAGON FLANGE BOLT	
14	90180602000	1	六角凸緣螺栓 (M6*20L)	HEXAGON FLANGE BOLT	

E9.1 化油器
CARBURETOR

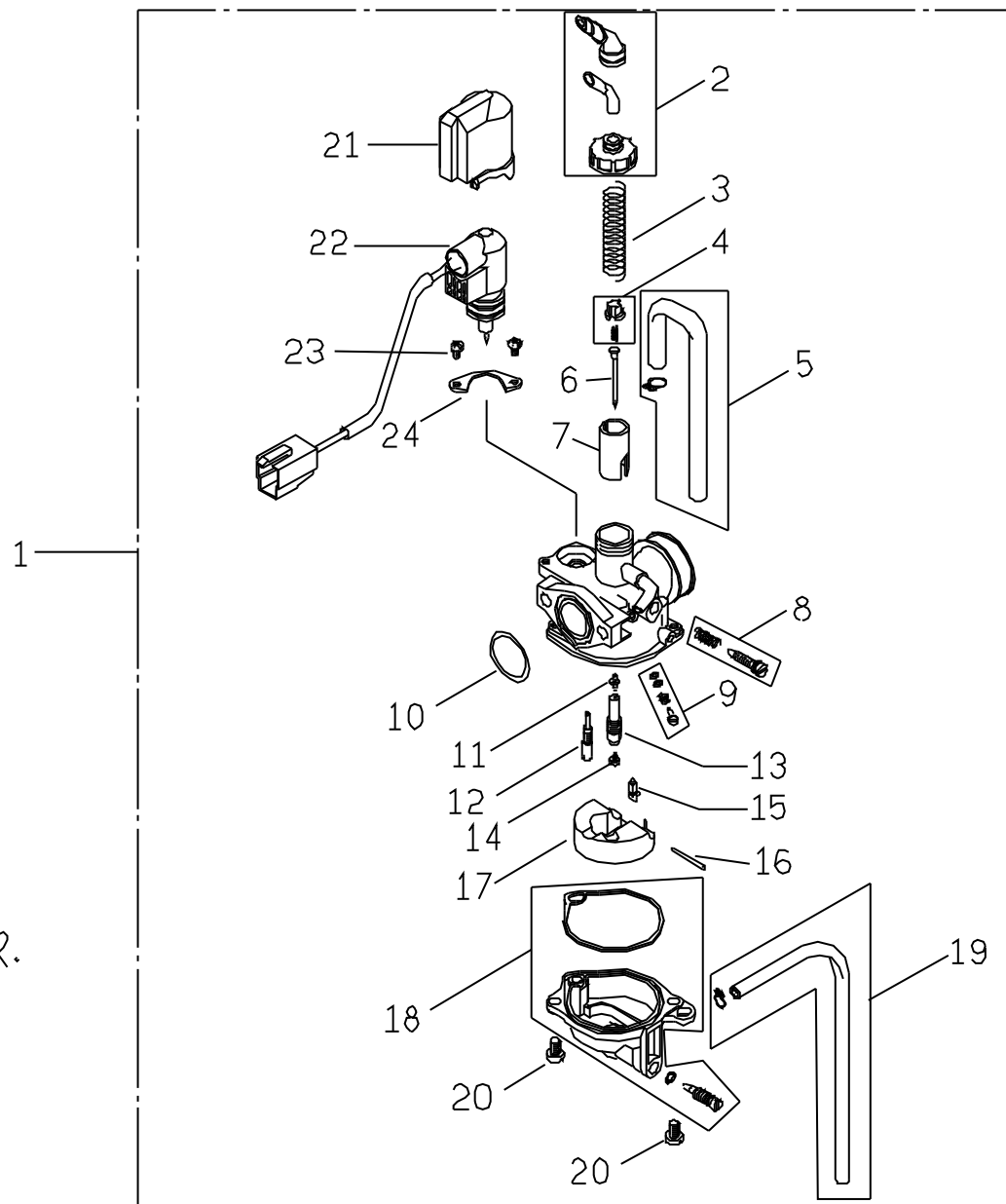

E9 CARBURETOR / 化油器

No.	Part No.	Q'TY	PART NAME	PART NAME	REMARK
項目	零件號碼	數量	零件中文名稱	零件英文名稱	備註
1	P5151000002	1	化油器總成	CARBURETOR ASSY.	SETTING "086"
2	D19KT-014-0100	1	上蓋	TOP SET	
3	D19KT-004-0200	1	壓縮彈簧	SPG., COMP.	
4	D19KT-001-0300	1	固定板	PLATE SET	
5	D19KT-027-2100	1	橡膠管	TUBE SET	
6	D19KT-037-0400	1	油針	JET NEEDLE	
7	D19KT-016-0500	1	節流閥	THROTTLE VALVE	
8	D19KT-003-1400	1	螺絲組	SCREW SET	
9	D19KT-009-1600	1	螺絲組	SCREW SET (S.S)	
10	D19KT-003-1500	1	O形環	O RING	
11	D19KT-014-0600	1	油針噴嘴	NEEDLE JET	
12	D19KT-067-1100	1	低速噴嘴 (#35)	SLOW JET	
13	D19KT-008-0900	1	油針噴嘴套管	HOLDER, NEEDLE JET	
14	D19KT-001-1000	1	主噴嘴 (#75)	JET, MAIN	
15	D19KT-003-0700	1	浮動閥組	FLOAT VALVE SET	
16	D19KT-001-0800	1	浮筒銷	PIN, ARM	
17	D19KT-003-1300	1	浮筒組	FLOAT SET	
18	D19KT-006-1200	1	油室組	FLOAT CHAMBER SET	
19	D19KT-026-2100	1	橡膠管組	TUBE SET	
20	D19KT-006-1900	2	墊片螺絲	SCREW, WASHER	
21	D19KT-002-2000	1	保溫蓋	CAP HOLDER	
22	D19KT-066-1700	1	自動旁通起動組	AUTO BYSTARTER SET	
23	D19KT-005-1900	2	墊片螺絲	SCREW, WASHER	
24	D19KT-001-1800	1	固定片	PLATE SET	

E10 空氣濾清器組合
AIR CLEANER COMP.

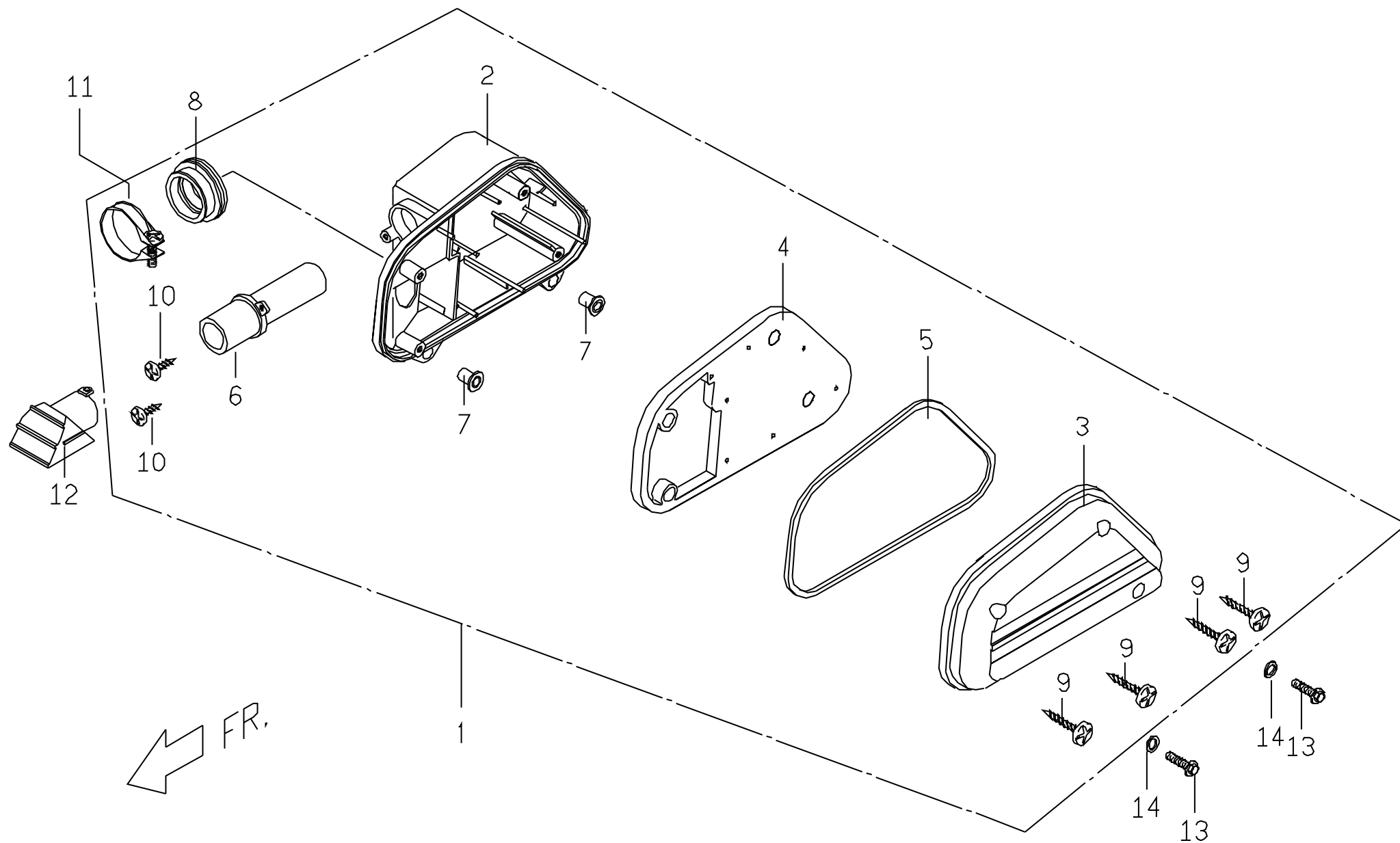

E10 AIR CLEANER / 空氣濾清器組合

No.	Part No.	Q'TY	PART NAME	PART NAME	REMARK
項目	零件號碼	數量	零件中文名稱	零件英文名稱	備註
1	P1262000001	1	空氣濾清器組合	AIR CLEANER COMP.	GENERAL
2	NA	1	空氣濾清器本體	BODY, AIR CLEANER	NOT SUPPLIED
3	P1262020000	1	空氣濾清器蓋	COVER, AIR CLEANER	
4	P1262030000	1	空氣濾清器過濾棉	SPONGE, AIR CLEANER	
5	P1262040000	1	空氣濾清器襯墊	PACKING, AIR CLEANER	
6	P12620500001	1	空氣管	AIR HOSE	
7	E9262060000	2	襯套	BUSH	
8	P1262080000	1	連接管	CONNECTION PIPE, AIR CLEANER	
9	90110502500	4	十字槽扁圓頭自攻螺釘	CR RECESS PAN HD. TAPPING	
10	90110401200	2	十字槽扁圓頭自攻螺釘	CR RECESS PAN HD. TAPPING	
11	P1262110000	1	管束	CLAMP	
12	P1262120000	1	進氣蓋	INTAKE COVER	
13	90180602500	2	六角凸緣螺栓 (M6*25L)	HEXAGON FLANGE BOLT	
14	92140600005	2	平墊圈	PLAIN WASHER	

E11 MUFFLER

CRANKCASE
左曲軸箱

SAI (optional device)

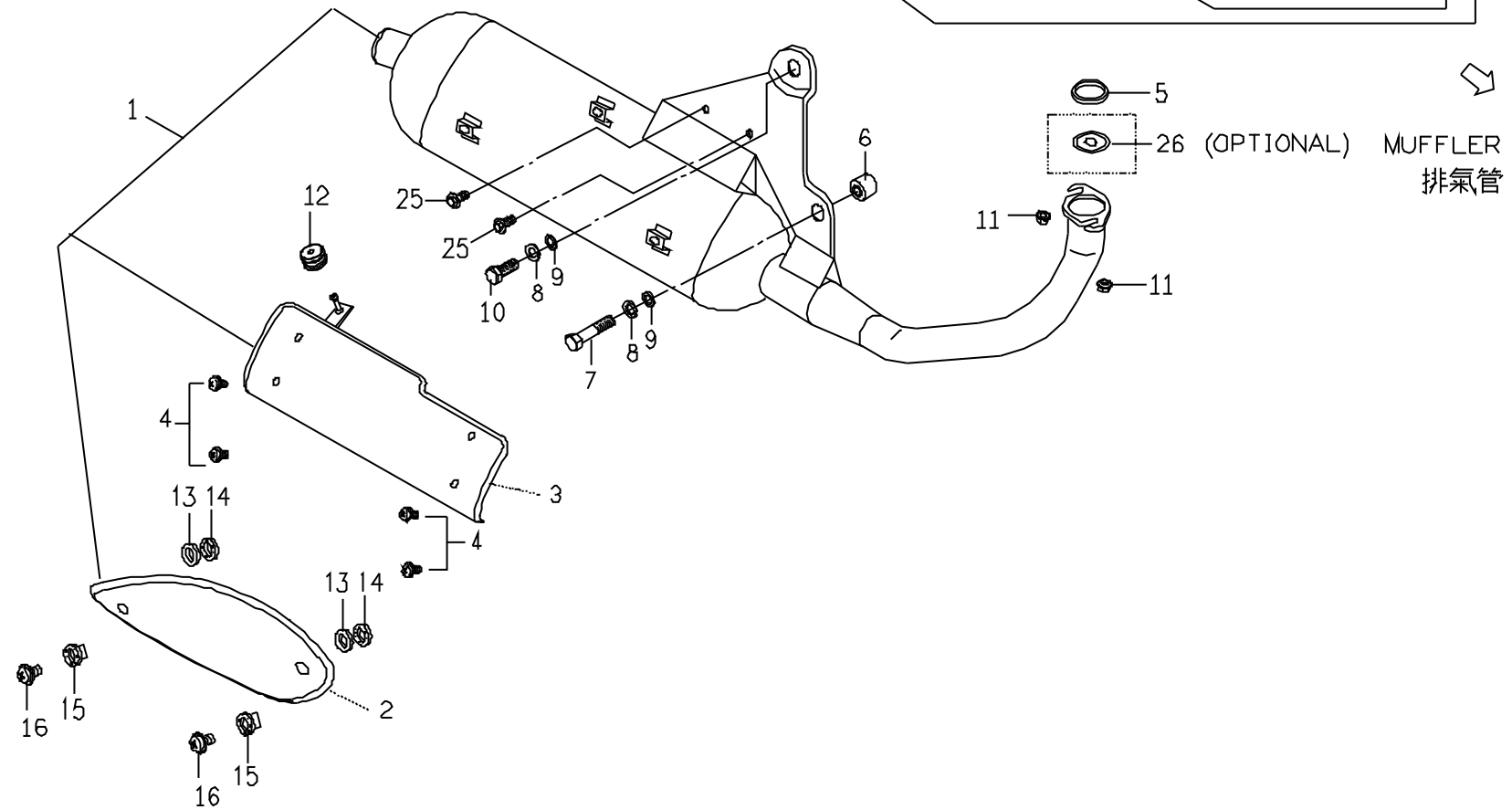

E11 MUFFLER / 消音器

No.	Part No.	Q'TY	PART NAME	PART NAME	REMARK
項目	零件號碼	數量	零件中文名稱	零件英文名稱	備註
1	P52810020004	1	消音器總成	MUFFLER ASSY.	
2	C22810100001	1	外隔熱板總成	OUTSIDE HEAT PROTECTOR ASSY	不含隔熱棉
3	P5281020000	1	內隔熱板總成	INSIDE HEAT PROTECTOR ASSY	
4	90050608000	4	十字槽圓頭帶墊圈機器螺釘	CR RECESS PAN HD. TAPPING	
5	E9281020000	1	排氣管墊片	GASKET, MUFFLER	
6	E1062020000	1	防震襯套	DAMPER BUSH	
7	90190804003	1	六角螺栓	HEXAGON BOLT	
8	92110800000	2	彈簧墊圈	SPRING WASHER	
9	92140800000	2	平墊圈	PLAIN WASHER	
10	90190802600	1	六角螺栓	HEXAGON BOLT	
11	90050602000	2	六角凸緣螺帽	HEXAGON FLANGE NUT	
12	P5281060000	1	固定橡膠	FIXING RUBBER	
13	C328A040000	2	鎖環	CIRCLET	
14	92140600015	2	耐高溫墊片	HIGH TEMPERATURE PLAIN WASHER	
15	C328A020000	2	鎖環內襯管	INNER SPACER	
16	90050602000	2	十字圓頭機器螺釘	C-R ROUND HD.TAPPING SCREW	

E12 REAR WHEEL

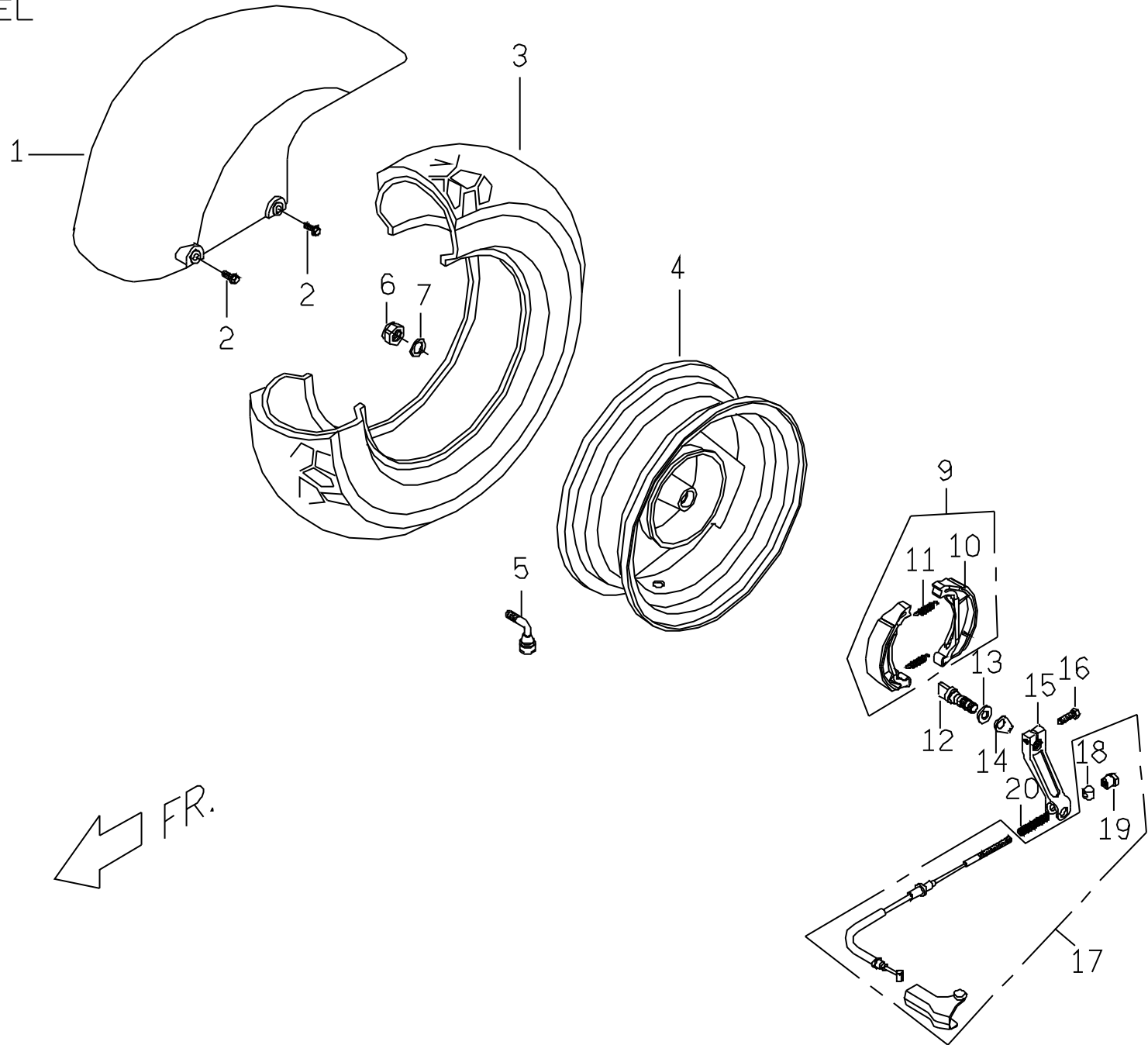

E12 REAR WHEEL / 後輪

No.	Part No.	Q'TY	PART NAME	PART NAME	REMARK
項目	零件號碼	數量	零件中文名稱	零件英文名稱	備註
1	P56340006501	1	後土除 (超黑色)	REAR FENDER	
2	90180602000	2	六角凸緣螺栓 (M6*20L)	HEXAGON FLANGE BOLT	
3	P540B320000	1	輪胎 (90/90-10)	TYRE	
4	P5407102770	1	後輪圈組合 (銀灰色)	RR WHEEL COMP.	
5	P140B330000	1	氣門嘴	VALVE	
6	92011600000	1	U型螺帽	U TYPE NUT	
7	92141700001	1	平墊圈	PLAIN WASHER	
8	E1407010000	1	防塵環	DUST RING	
9	E14074000002	1	後煞車蹄片總成	BRAKE SHOE ASSY.	
12	E1407440000	1	後煞車凸輪	CAM, RR BRAKE	
13	95511000002	1	O形環		
14	E1407450000	1	後煞車指示器	INDICATOR, RR BRAKE	
15	P1407471000	1	後煞車臂	ARM, RR BRAKE	
16	90020602202	1	六角螺栓	HEXAGON BOLT	
17	P5544401000	1	後煞車導線總成	CABLE ASSY., RR BRAKE	
18	E1544440000	1	銷	PIN	
19	E1544410000	1	導線調整螺帽	ADJUST NUT, CABLE	
20	E1544420000	1	後煞車回覆彈簧	SPRING, RR BRAKE ARM	

E13 STAND

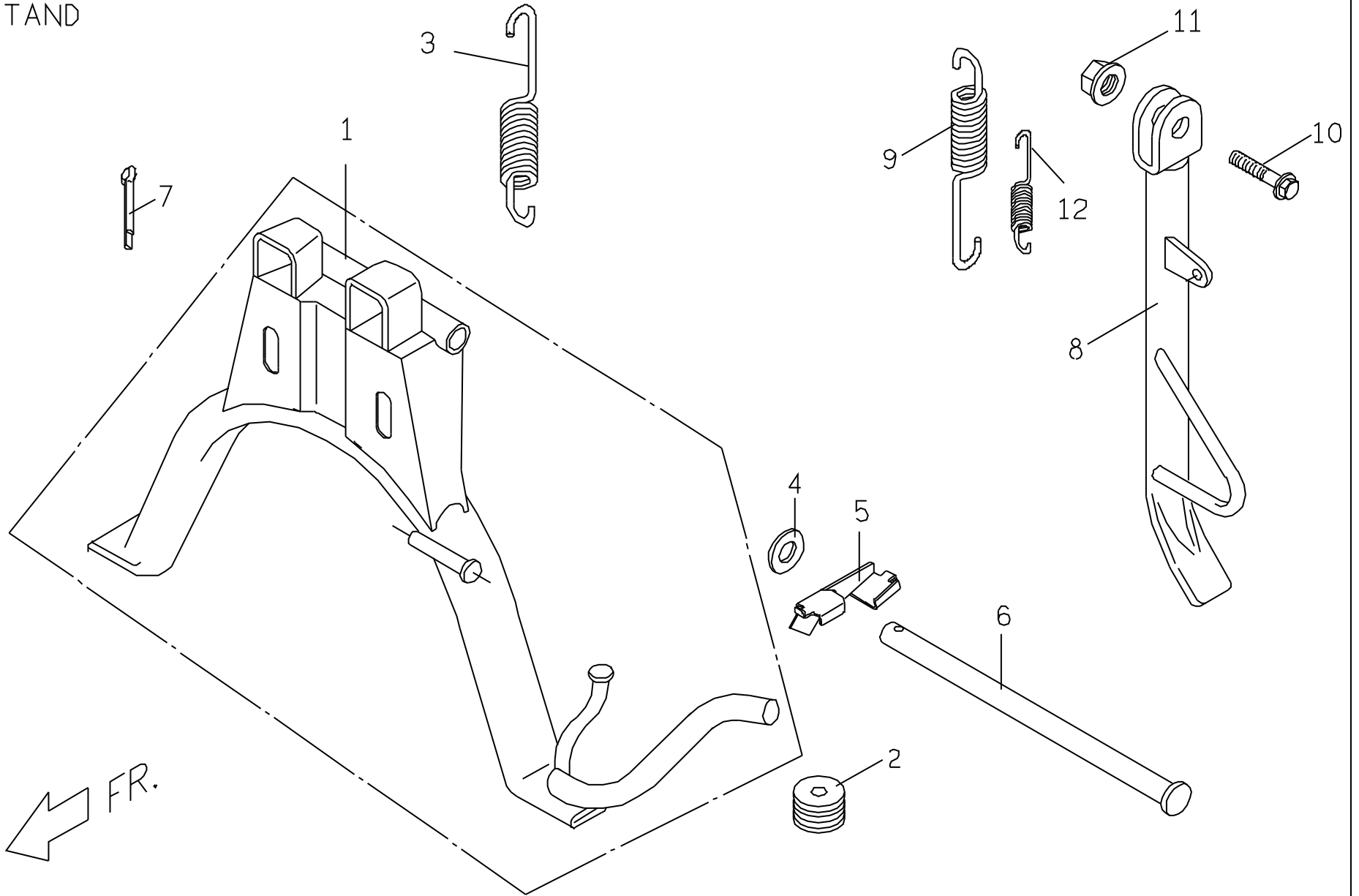

E13 STANDS / 中腳柱・側腳柱

No.	Part No.	Q'TY	PART NAME	PART NAME	REMARK
項目	零件號碼	數量	零件中文名稱	零件英文名稱	備註
1	P5461001600	1	中腳柱組合 (E.D)	CENTER STAND ASSY	
2	P146A011000	1	中腳柱緩衝橡膠	RUBBER DAMPING, CENTER STAND	
3	P1461120000	1	中腳柱彈簧 (黑色)	SPRING, CENTER STAND	
4	P1701070000	1	橡膠墊圈	RUBBER WASHER	
5	P1407482000	1	後煞車導線固定板	RR BREKE FIXING PLATE	
6	E1461110000	1	中腳柱固定銷	CRT STD FIXING PIN	
7	93561010000	1	R型插銷	SPILT PIN	
8	P5462002600	1	側腳柱總成 (E.D)	SIDE SAND ASSY.	
9	C2462120000	2	側腳柱彈簧 (墨綠色)	SIDE STAND SPRING	
10	90191002800	3	六角凸緣螺栓	HEXAGON FLANGE BOLT	
11	92061000000	1	U型螺帽	U TYPE NUT	
12	P5462010000	1	側腳柱內彈簧	SIDE STAND INNER SPRING	

F1

方向把手上下蓋。方向把手管。頭燈
COVER UPPER & LOWER, HANDLE BAR.
HEADLAMP

← FR.

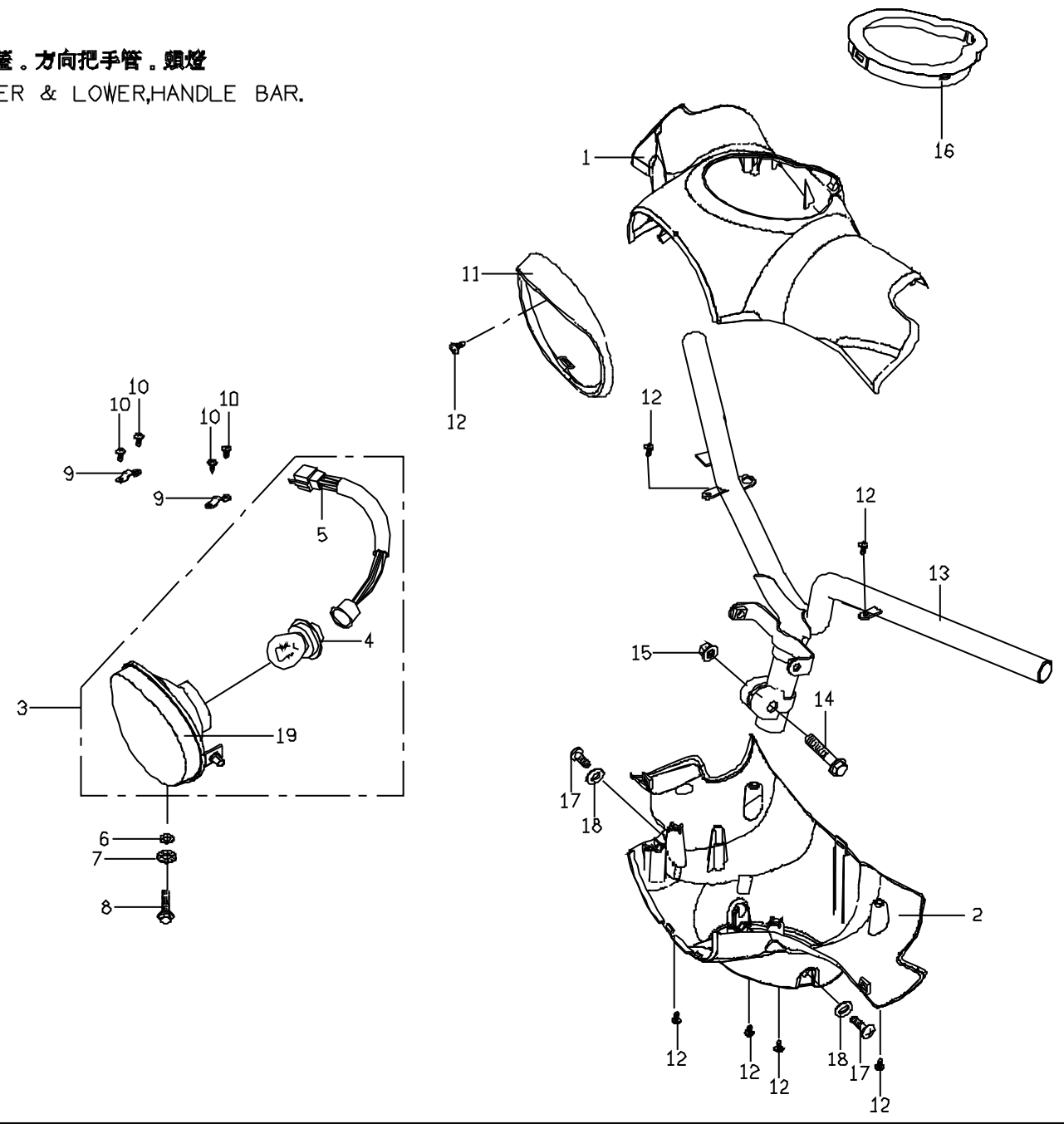

F1. 方向把手上下蓋 可動 / STEERING COVER MOVABLE MODEL

No.	Part No.	Q' TY	PART NAME	PART NAME	REMARK
項目	零件號碼	數量	零件中文名稱	零件英文名稱	備 註
1	P56130004W0	1	方向把手上蓋 (碟)	COVER,UPPER	BLUE
1	P5613000710	1	方向把手上蓋 (碟)	COVER,UPPER	WHITE
1	P5613000690	1	方向把手上蓋 (碟)	COVER,UPPER	BLACK
2	P5614000670	1	方向把手下蓋	COVER,LOWER	
3	P5661000000	1	頭燈組合(內銷)	HEADLIGHT COMP	
4	98111235301	1	燈炮(內銷)	BULB	
5	P566A040000	1	電線組(內銷)	CONNECTING WIRE	
6	92140500014	1	平墊圈	PLAIN WASHER	
7	92130600000	1	齒形墊圈	WASHER	
8	E1613010000	1	調整螺栓	REGULATING SCREW	
9	P5706010000	2	頭燈壓板	FRONT LIGHT PLATE	
10	90130301000	4	十字槽盤頭自攻螺釘	C-R RECESS PAN HD TAPPING SCREW	
11	P5613030000	1	前燈罩	FR.HEAD LIGHT COVER	
12	90110401200	7	十字槽盤頭自攻螺釘	C-R RECESS PAN HD TAPPING SCREW	
13	P5612001600	1	方向把手管總成	HANDLE BAR ASSY	
14	90191004600	1	六角凸緣螺栓	HEXAGON FLANGE BOLT	
15	92061000001	1	六角凸緣螺帽	HEXAGON LOCK NUT	
16	P5613020000	1	碼錶飾蓋	SPEED METER SIDE COVER	
17	90040601400	2	十字槽盤頭自攻螺釘	C-R RECESS PAN HD TAPPING SCREW	
18	92140600000	2	平墊圈	PLAIN WASHER	
19	P566A060000	1	燈座組合(內銷)	LAMP COMP	

F2 碼 錶
SPEEDOMETER

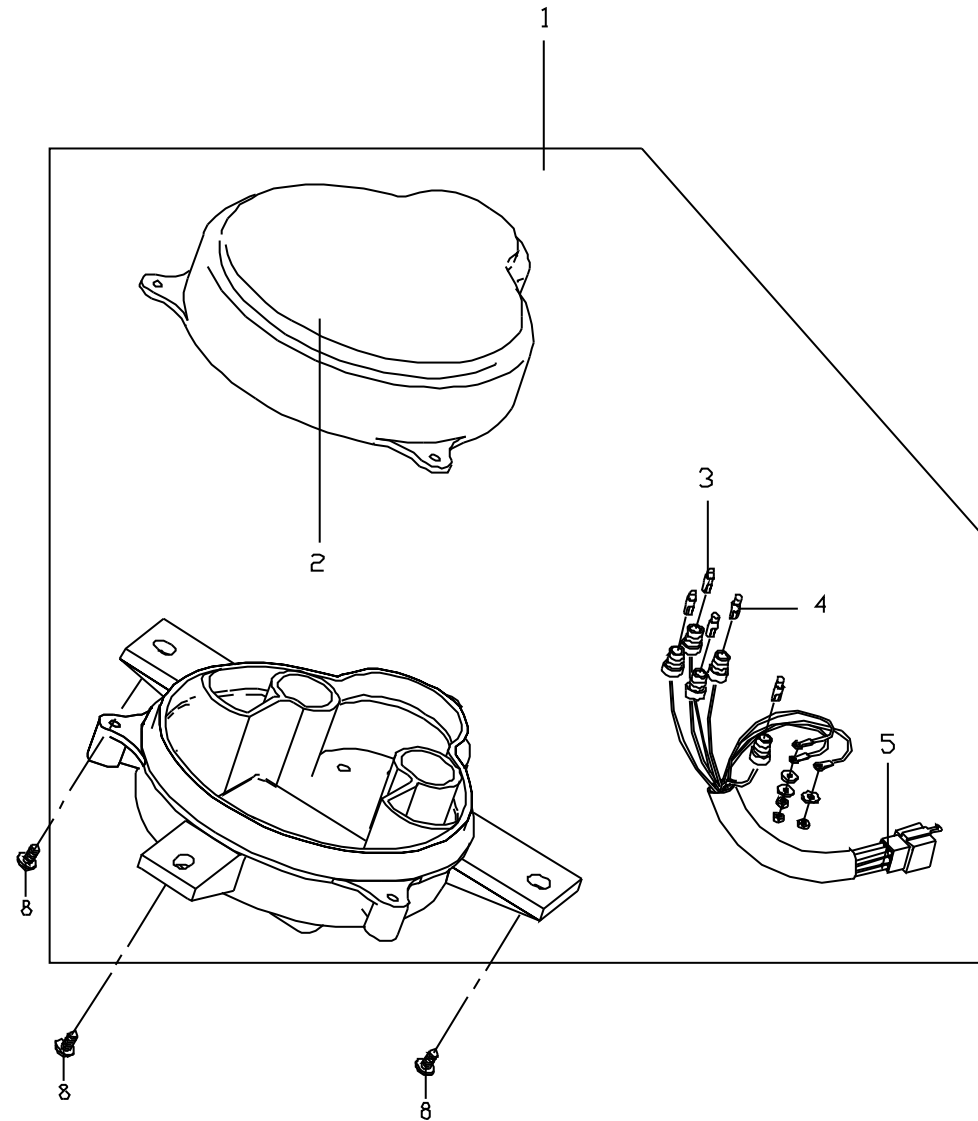
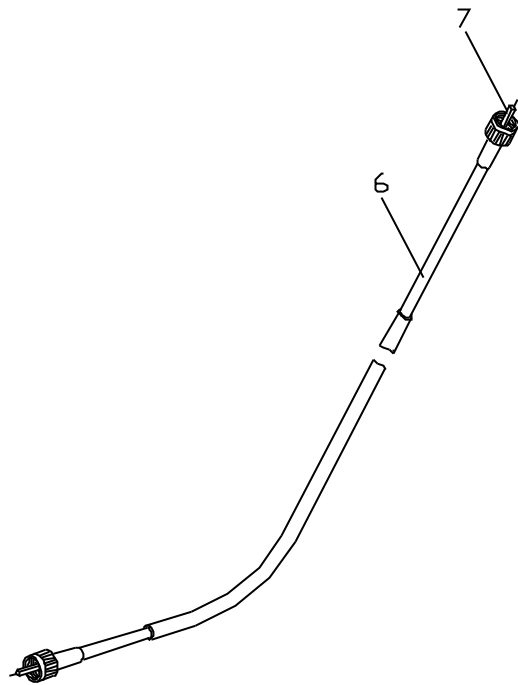

F2. 碼錶 / SPEEDOMETER

No.	Part No.	Q' TY	PART NAME	PART NAME	REMARK
項目	零件號碼	數量	零件中文名稱	零件英文名稱	備註
1	P5561000005	1	碼錶總成	SPEEDMETER ASSY	
2	P556A010000	1	錶鏡	COVER UPPER	
3	P556A030000	1	燈炮組 (3W)	BULB	
4	P556A020000	5	燈炮組 (1.7W)	BULB	
5	P556A040000	1	電線組	CONNECTING WIRE	
6	P5544003000	1	碼錶導線總成(碟式)	SPEEDMETER CABLE ASSY	
7	P554D060000	1	內線(碟式)	INNER WIRE	
8	90130501400	3	十字槽盤頭自攻螺釘	C-R RECESS PAN HD TAPPING SCREW	

F3 導線。開關。後視鏡 (碟式)
 CABLE.SWITCH.BACK MIRROR

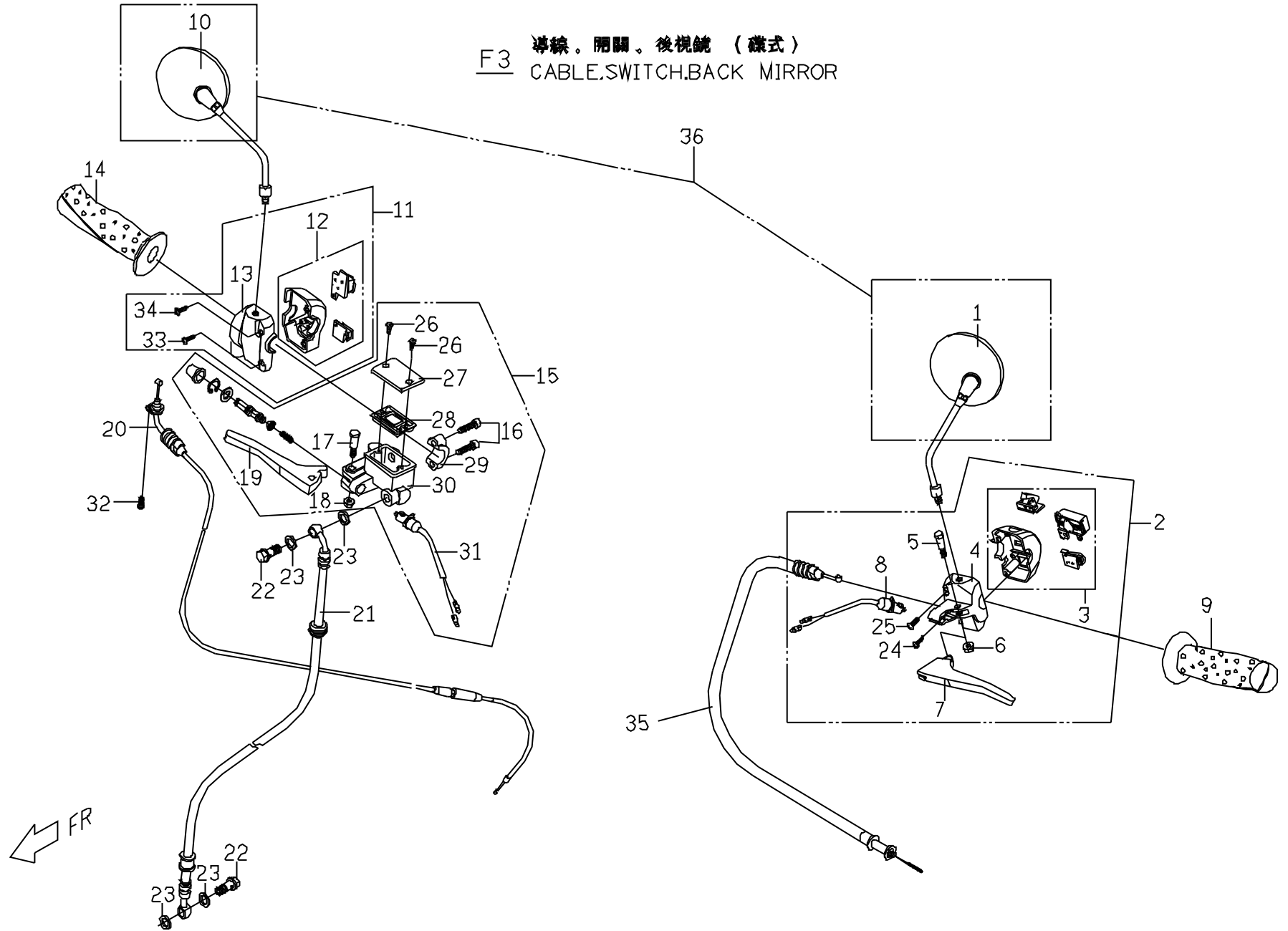

F3. 導線。開關。後視鏡 / CABLES, SWITCH

No.	Part No.	Q' TY	PART NAME	PART NAME	REMARK
項目	零件號碼	數量	零件中文名稱	零件英文名稱	備註
1	P561F0100001	1	左後視鏡 (電鍍件)	LH BACK MIRROR	
2	P1546003000	1	左把手開關總成	LEVER HOLDER ASSY(LEFT)	
3	P154F410000	1	內夾持板2組合	CASE,SWITCH UNDER 2 COMP	
4	P154F020000	1	內夾持板1	CASE,SWITCH UNDER 1	
5	P154F030000	1	螺栓	BOLT	
6	P154F040000	1	防鬆螺帽	LOCK NUT	
7	P1543303000	1	左煞車拉桿	LEVER,LH BRAKE	
8	P154F050000	1	左安全開關	RR BRK SWITCH COMP	
9	P0541000000	1	左握把護套	LH GRIP ASSY	
10	P561F0200001	1	右後視鏡 (電鍍件)	RH BACK MIRROR	
11	P1548003000	1	右把手開關總成	LEVER HOLDER ASSY(RIGHT)	
12	P154H190000	1	內夾持板2組合	CASE,SWITCH UNDER 2 COMP	
13	P154H020000	1	內夾持板1	CASE,SWITCH UNDER 1	
14	P0542000000	1	右握把總成	RH GRIP ASSY	
15	P5403000000	1	前煞車總泵	FRT BRAKE MASTER CYLINDER	
16	P140C250000	2	內六角螺栓	HEX SOCKET HEAD BOLT	
17	P140C220000	1	螺栓	BOLT	
18	P140C230000	1	凸緣螺帽	FLANGE NUT	
19	P140C191000	1	右煞車拉桿	LEVER,RH BRAKE	
20	P5544601000	1	加油導線總成	CABLE ASSY,THROT	
21	P5403600000	1	煞車油管總成	FRT BRAKE FLUID HOSE COMP	

F3. 導線。開關。後視鏡 / CABLES, SWITCH

No.	Part No.	Q' TY	PART NAME	PART NAME	REMARK
項目	零件號碼	數量	零件中文名稱	零件英文名稱	備註
22	P1403810000	2	煞車油管通油螺栓	JOINT BOLT,BRAKE HOSE	
23	92141000002	4	平墊圈	PLAIN WASHER	
24	P154F390000	1	埋頭螺釘	SCREW,PAN HEAD	
25	P154F400000	1	埋頭螺釘	SCREW,PAN HEAD	
26	P140C130000	2	螺絲	SCREW	
27	P140C120000	1	油杯蓋	CAP,RESERVOIR	
28	P140C110000	1	皮膜	DIAPHRAGM,RESERVOIR	
29	P140C240000	1	夾持具	BRACKET,MASTER CYLINDER	
30	NA	1	缸體	MASTER CYLINDER	
31	P140C180000	1	右安全開關	SWITCH COMP	
32	90050501200	1	十字槽圓頭自攻螺釘	C-R RECESS PAN HD TAPPING SCREW	
33	P154H180000	1	十字槽圓頭螺栓	C-R ROUND HD TAPPING	
34	P154H170000	1	十字槽圓頭螺栓	C-R ROUND HD TAPPING	
35	P5544401000	1	後煞車導線總成	CABLE ASSY. RR BRAKE	
36	P56160000001	1	後視鏡總成 (電鍍件)	BACK MIRROR ASSY	

F4 前叉(碟),前土除
FRONT FORK,FR FENDER

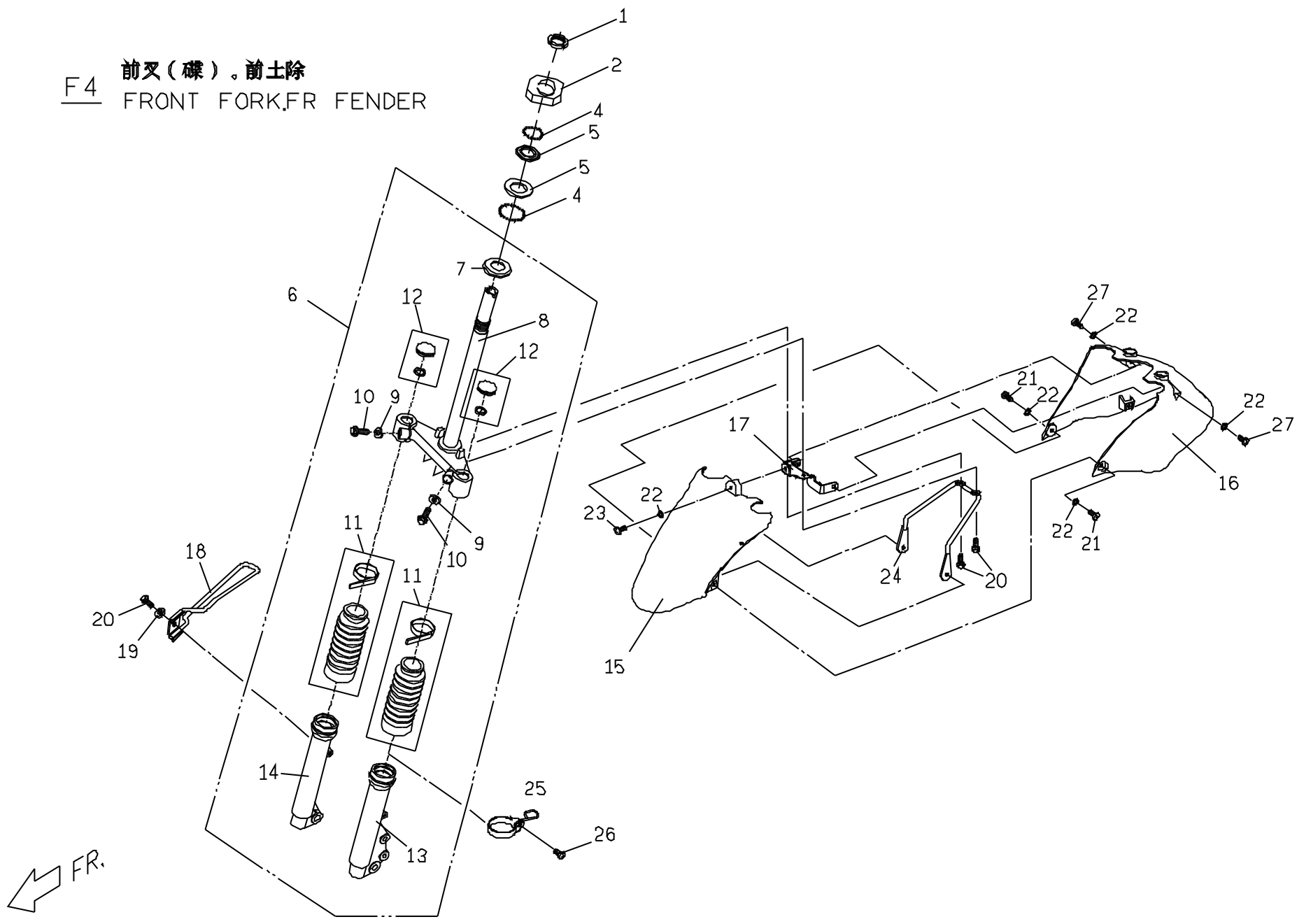

F4. 前叉(碟)・前土除_可動 / FRONT FORK MOVABLE MODEL

No.	Part No.	Q' TY	PART NAME	PART NAME	REMARK
項目	零件號碼	數量	零件中文名稱	零件英文名稱	備註
1	P1443040000	2	轉向軸防鬆螺帽	STEERING SHAFT LOCK NUT	
2	P6444051000	1	上座環形螺帽	UPPER BEARING CAGE	
4	9901050000	44	鋼珠	BEARING BALL	
5	P1443020000	2	軸承外座	OUTER BEARING CAGE	
6	P54430020001	1	前叉總成	FRONT FORK ASSY	
7	P1443010000	1	下軸承內座	LOWER INNER BEARING CAGE	
8	P544C2010001	1	下三角架組	UNDER BRACKET,COMP	
9	P144C020000	2	彈簧墊圈	SPRING WASHER	
10	P144C030000	2	螺栓	BOLT	
11	P144C040000	2	橡膠套管組	COVER,COMP	
12	P544C050000	2	內筒塞組	BOLT,COMP	
13	P544C2110001	1	左外筒總成	LH OUTER TUBE ASSY	
14	P544C2210001	1	右外筒總成	RH OUTER TUBE ASSY	
15	P56320004W0	1	前土除前段	FR SECTION FRONT FENDER	BLUE
15	P5632000710	1	前土除前段	FR SECTION FRONT FENDER	WHITE
15	P5632000690	1	前土除前段	FR SECTION FRONT FENDER	BLACK
16	P5632600670	1	前土除後段	RR SECTION FRONT FENDER	
17	P5632010600	1	前土除固定板	FRT.FENDER FIXING PLATE	
18	E9544021000	1	導線束圈	CABLE CLIP COMP	
19	9211080000	1	彈簧墊圈	SPRING WASHER	
20	90190601601	3	六角凸緣螺栓	HEXAGON FLANGE BOLT	
21	90040601400	2	十字槽盤頭機器螺釘	C-R PAN HD.MACHINE SCREW	
22	92140600005	5	平墊圈	PLAIN WASHER	
23	90040601601	1	十字槽盤頭機器螺釘	C-R PAN HD.MACHINE SCREW	
24	P5632020600	1	前土除固定架	FRT.FENDER FIXING FRAME	

F5 輪胎。前輪圈。碟式煞車夾
TIRE.FRT WHEEL.FRT CALIPER.

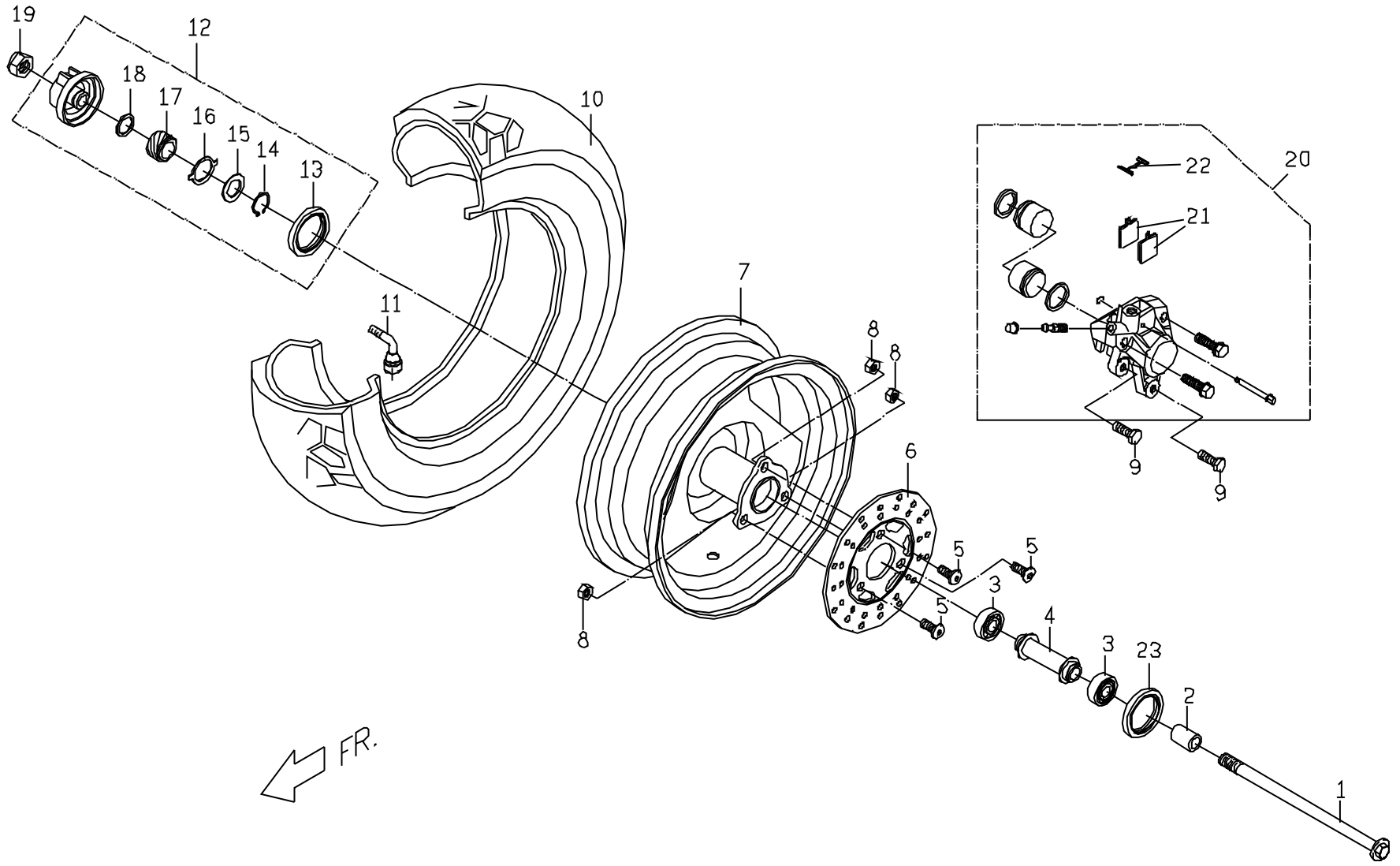

F5. 輪胎。前輪圈。/ FRONT WHEEL

No.	Part No.	Q' TY	PART NAME	PART NAME	REMARK
項目	零件號碼	數量	零件中文名稱	零件英文名稱	備註
1	P5402500000	1	前輪軸	AIX FR WHEEL	
2	P1401010000	1	間隔環	SPACER	
3	96520620100	2	單封深槽滾珠軸承	ONE SHLIED BALL BEARING	
4	P5402400000	1	間隔環組合	SPACER COMP	
5	E1403512000	3	前煞車盤螺絲	BLOT,FRT BRK DISK	
6	P1403500000	1	前煞車圓盤	DISC FRONT BRAKE	
7	P5401102770	1	前輪圈組合(碟式)	FRT WHEEL RIM COMP	
8	92400800001	3	防鬆螺帽	LOCK NUT	
9	90190803002	2	六角頭螺栓	HEXAGON HEAD BOLT	
10	P540G320000	1	前輪胎總成(華豐)	FRONT WHEEL ASSY	
11	P140B330000	1	氣門嘴	VAVLE	
12	C1566002000	1	碼錶齒輪總成	METER GEAR ASSY	
13	95574052600	1	油封	OIL SEAL	
14	92171800000	1	C型扣環	C CLIP	
15	92141900001	1	平墊圈	PLAIN WASHER	
16	P1566050000	1	傳動片	PAD	
17	C1566040000	1	速度錶齒輪	SPEEDMETER GEAR	
18	92141900002	1	平墊圈	PLAIN WASHER	
19	92061200001	1	防鬆螺帽	LOCK NUT	
20	P5403300000	1	前煞車夾總成	FRT BRAKE CLIPPER	
21	P540C310000	1	煞車片組成	PAD	
22	P540C320000	1	軛簧	YOKE SPRING	
23	95572235700	1	油封	OIL SEAL	

F6 擋風板，前內蓋，前下蓋
 WINDSHIELD, FRT INNER COVER,

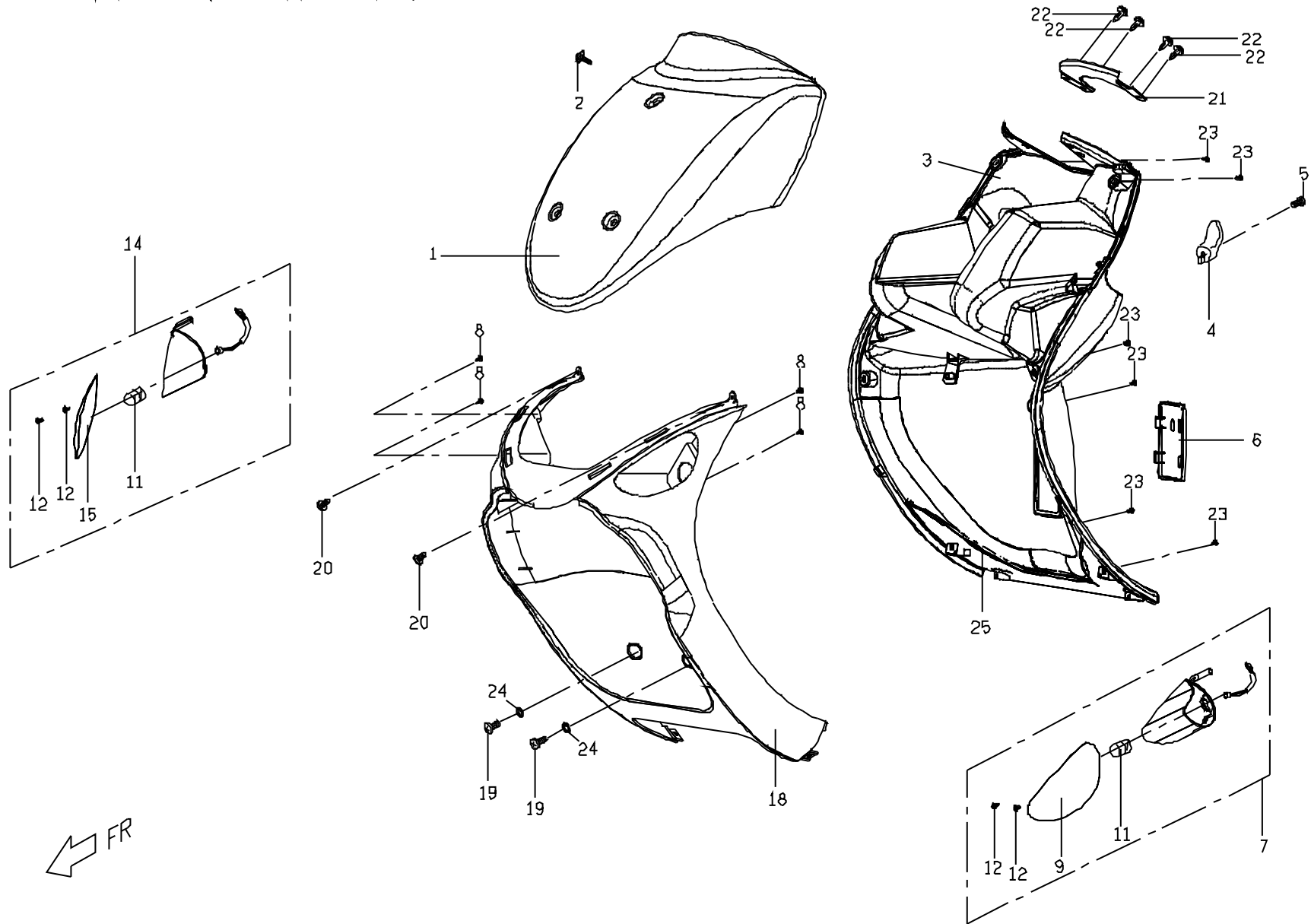

F6. 擋風板。前內蓋 可動 / WINDSHIELD MOVABLE MODEL

No.	Part No.	Q' TY	PART NAME	PART NAME	REMARK
項目	零件號碼	數量	零件中文名稱	零件英文名稱	備 註
1	P56210004W0	1	擋風板	WINDSHIELD	BLUE
1	P5621000710	1	擋風板	WINDSHIELD	WHITE
1	P5621000690	1	擋風板	WINDSHIELD	BLACK
2	E1621010000	1	帶墊圈圓頭機器螺釘	SCREW WITH WASHER	
3	P5623030670	1	前內蓋上段	FRT INNER COVER,UPPER	
4	P5701211670	1	前置物掛勾	FRONT HOOK	
5	90040602003	1	十字槽盤頭機器螺釘	C-R PAN HD.MACHINE SCREW	
6	P5623010670	1	車身號碼牌蓋	ADHESIVE PAPER	
7	P566C0100002	1	左前方向燈	POSTION LAMP,LH	
8	90110401200	4	自攻螺絲	TAPPING SCREW	
9	P566C0200002	1	左燈罩	POSTION LAMP COVER,LH	
11	98211210990	2	燈泡	BULB	
12	P566C050000	4	十字圓頭自攻螺釘	C-R RECESS PAN HD TAPPING SCREW	
14	P566D0100002	1	右前方向燈	POSTION LAMP ,RH	
15	P566D0200002	1	右燈罩	POSTION LAMP COVER,RH	
18	P56260134W0	1	前下蓋	COVER,FRT LOWER	BLUE
18	P5626013710	1	前下蓋	COVER,FRT LOWER	WHITE
18	P5626013690	1	前下蓋	COVER,FRT LOWER	BLACK
19	90040601400	2	十字槽盤頭機器螺釘	C-R PAN HD.MACHINE SCREW	
20	90130501400	2	自攻螺絲	TAPPING SCREW	
21	P5623020670	1	前內蓋飾蓋	FRONT PANEL,INNER COVER	
22	E1701040000	4	螺旋鉚釘組合	SCRIVET COMP	
23	90130501400	6	自攻螺絲	TAPPING SCREW	
24	92140600005	2	平墊圈	PLAIN WASHER	
25	P5623040670	1	前內蓋下段	FRT INNER COVER,LOWER	

F7 脚踏板。电瓶。左右边饰盖
STEPFLOOR,BATTERY,
LH,RH SIDE COVER.

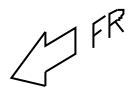
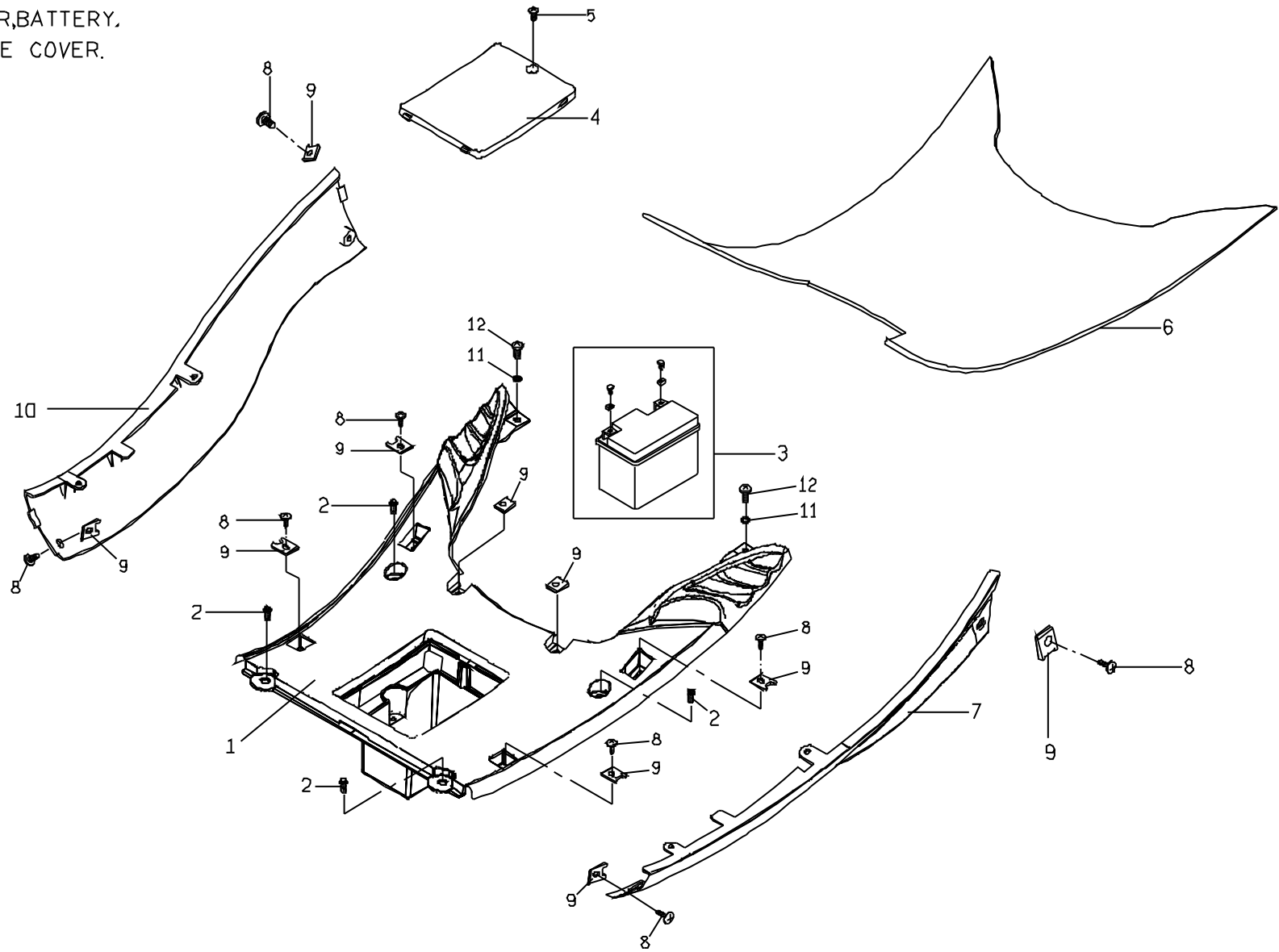

F7. 腳踏板。左右邊飾蓋 / STEPFLOOR

No.	Part No.	Q' TY	PART NAME	PART NAME	REMARK
項目	零件號碼	數量	零件中文名稱	零件英文名稱	備註
1	P5624001670	1	腳踏板	STEP FLOOR	
2	90200602500	4	帶墊圈螺栓	SCREW WITH WASHER	
3	P5583000000	1	電瓶	BATTERY	
4	P5624030670	1	電瓶蓋	BATTERY COVER	
5	90130501400	1	自攻螺絲	TAPPING SCREW	
6	P5624501670	1	腳踏板橡皮墊	MAT FLOOR	gray
7	P56263034W0	1	左邊飾蓋(顏色件見附表)	LH SIDE COVER	BLUE
7	P5626303710	1	左邊飾蓋(顏色件見附表)	LH SIDE COVER	WHITE
7	P5626303690	1	左邊飾蓋(顏色件見附表)	LH SIDE COVER	BLACK
8	90130501400	8	自攻螺絲	TAPPING SCREW	
9	92370500003	10	U型彈簧螺帽	SPRING NUT U-TYPE	
10	P56265014W0	1	右邊飾蓋(顏色件見附表)	RH SIDE COVER	BLUE
10	P5626501710	1	右邊飾蓋(顏色件見附表)	RH SIDE COVER	WHITE
10	P5626501690	1	右邊飾蓋(顏色件見附表)	RH SIDE COVER	BLACK
11	92140600005	2	平墊圈	PLAIN WASHER	
12	90040601400	2	十字槽盤頭機器螺釘	C-R PAN HD.MACHINE SCREW	

F8 車身蓋。前胸蓋。後行李架。
BODY COVER, MIDDLE COVER
RR LUGGAGE

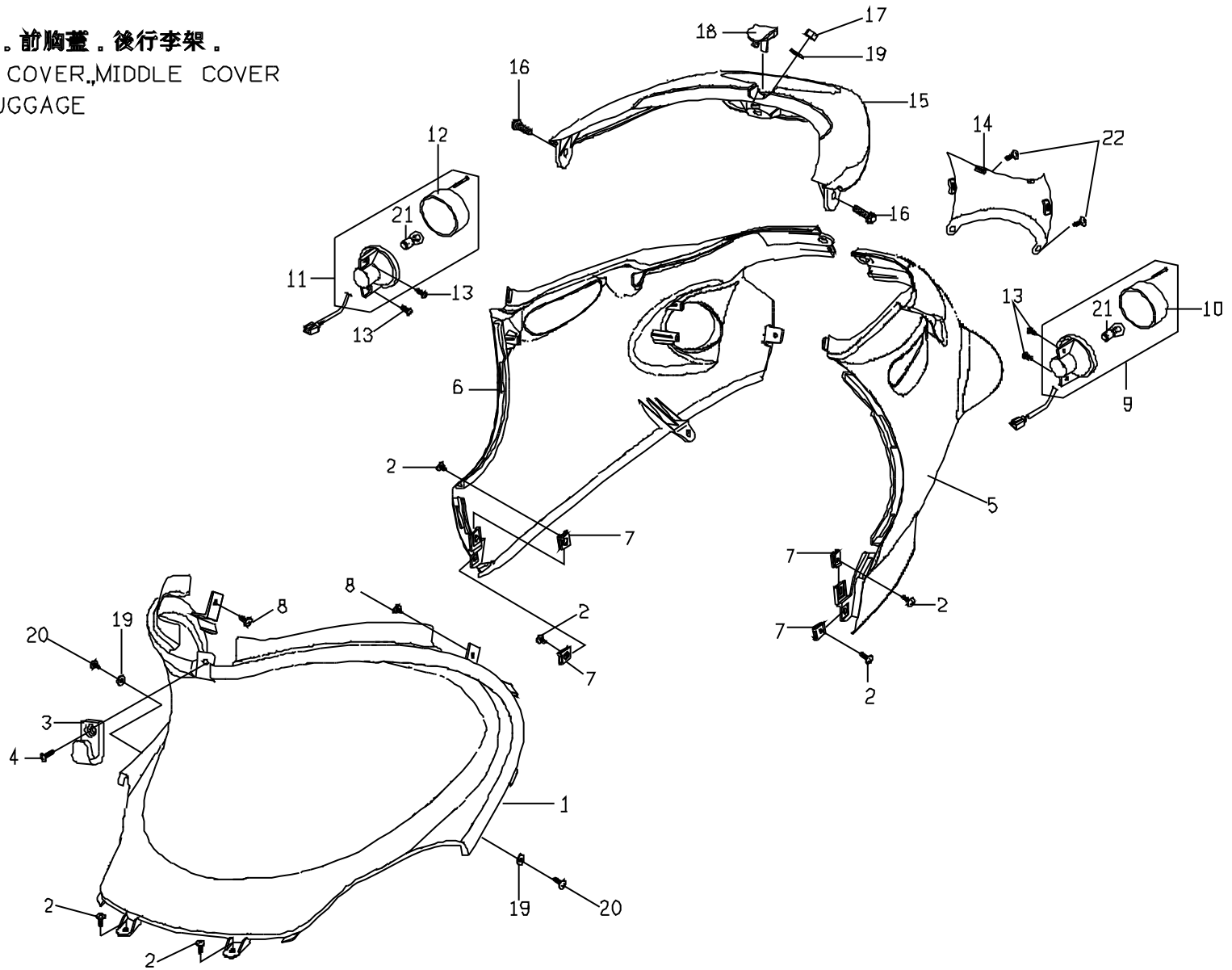

F8. 車身蓋。前胸蓋。後行李架 / BODY COVER

No.	Part No.	Q' TY	PART NAME	PART NAME	REMARK
項目	零件號碼	數量	零件中文名稱	零件英文名稱	備註
1	P5625041670	1	前胸蓋	BODY COVER,FRONT	
2	90150501601	6	自攻螺絲	C-R RECESS PAN HD.TAPPING SCREW	
3	P5701220670	1	後置物掛鉤	RR HOOKHELMET ASSY	
4	90040601601	1	十字槽圓頭機器螺釘	C-R RECESS PAN HD.TAPPING SCREW	
5	P56253004W0	1	左車身蓋(顏色件見附表)	LH BODY COVER	BLUE
5	P5625300710	1	左車身蓋(顏色件見附表)	LH BODY COVER	WHITE
5	P5625300690	1	左車身蓋(顏色件見附表)	LH BODY COVER	BLACK
6	P56255004W0	1	右車身蓋(顏色件見附表)	RH BODY COVER	BLUE
6	P5625500710	1	右車身蓋(顏色件見附表)	RH BODY COVER	WHITE
6	P5625500690	1	右車身蓋(顏色件見附表)	RH BODY COVER	BLACK
7	92370500003	4	U型彈簧螺帽	SPRING NUT U-TYPE	
8	90130501400	2	自攻螺絲	C-R RECESS PAN HD.TAPPING SCREW	
9	P566G0110002	1	左後方向燈組合	LH RR SIGNAL LAMP ASSY	
10	P566G0200002	1	左後方向燈蓋	LH RR SIGNAL LAMP COVER	
11	P566H0110002	1	右後方向燈組合	RH RR SIGNAL LAMP ASSY	
12	P566H0200002	1	右後方向燈蓋	RH RR SIGNAL LAMP COVER	
13	90110401200	4	自攻螺絲	C-R RECESS PAN HD.TAPPING SCREW	
14	P56257004W0	1	後蓋(塗裝件)	REAR COVER	BLUE
14	P5625700710	1	後蓋(塗裝件)	REAR COVER	WHITE
14	P5625700690	1	後蓋(塗裝件)	REAR COVER	BLACK
15	P56760014W0	1	後行李架(塑膠)	RR LUGGAGE BRACRET	BLUE
15	P5676001710	1	後行李架(塑膠)	RR LUGGAGE BRACRET	WHITE
15	P5676001690	1	後行李架(塑膠)	RR LUGGAGE BRACRET	BLACK
16	90190602002	2	六角凸緣螺栓	HEXAGON FLANGE BOLT	
17	92040600003	1	六角凸緣螺帽	HEXAGON FLANGE NUT	

F8. 車身蓋。前胸蓋。後行李架 / BODY COVER

No.	Part No.	Q' TY	PART NAME	PART NAME	REMARK
項目	零件號碼	數量	零件中文名稱	零件英文名稱	備註
18	P56760204W0	1	後行李架飾蓋	RR LUGGAGE BRAKET	BLUE
18	P5676020710	1	後行李架飾蓋	RR LUGGAGE BRAKET	WHITE
18	P5676020690	1	後行李架飾蓋	RR LUGGAGE BRAKET	BLACK
19	92140600017	3	平墊圈	PLANE WASHER	
20	90040601400	2	十字槽盤頭機器螺釘	C-R RECESS PAN HD.TAPPING SCREW	
21	98211210990	2	方向燈泡	BULB, SIGNAL LAMP	
22	90130501400	2	自攻螺絲	C-R RECESS PAN HD.TAPPING SCREW	

F9

座墊。置物箱。工具包。置物箱底蓋

SEAT.LUGGAGE.TOOL KIT.
LUGGAGE LOW COVER

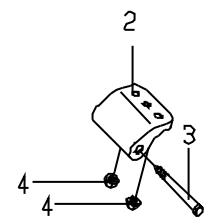
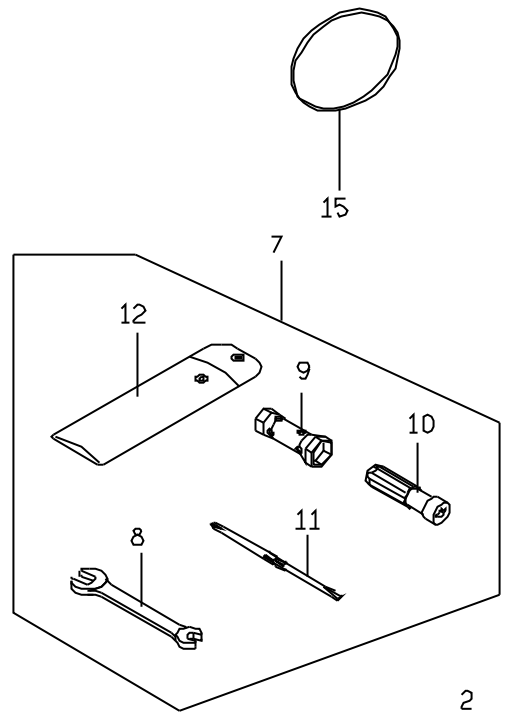

FR

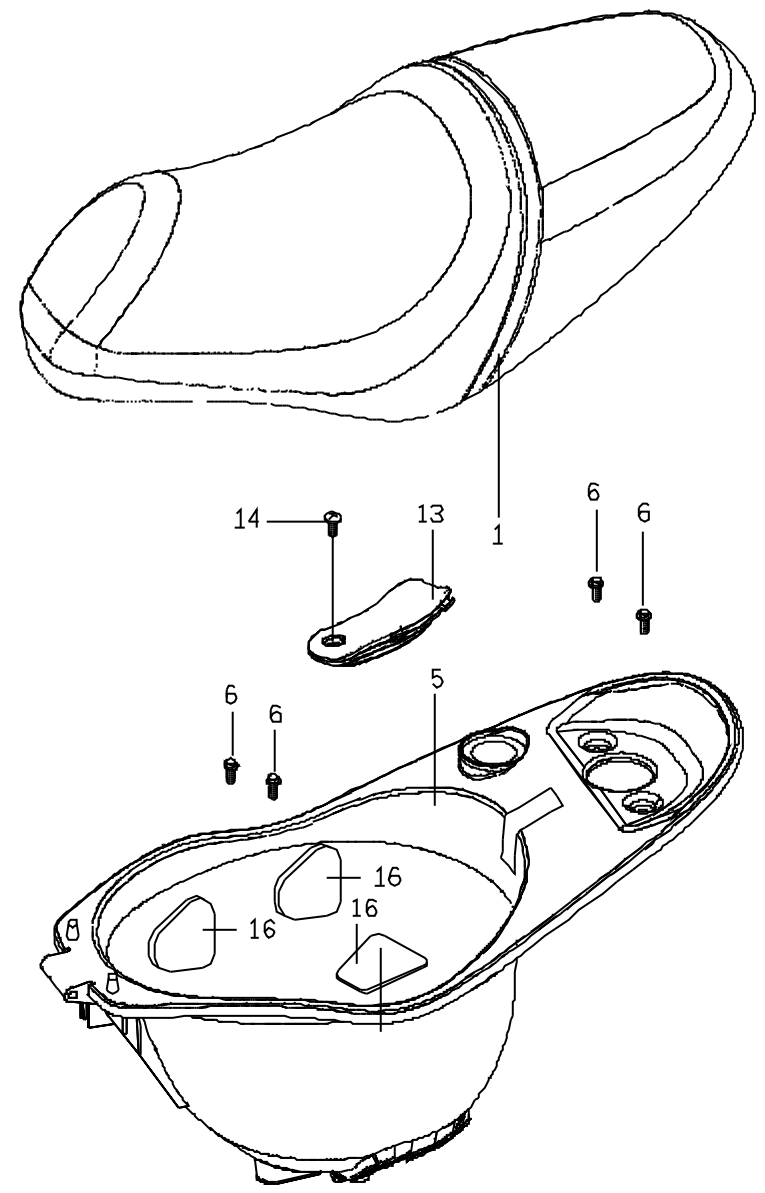

F9. 座墊。置物箱 / SEAT

No.	Part No.	Q' TY	PART NAME	PART NAME	REMARK
項目	零件號碼	數量	零件中文名稱	零件英文名稱	備註
1	P56710010001	1	座墊總成 (咖啡色)	SEAT ASSY	
2	P1681061000	1	前取付	BRACKET	
3	P1681071000	1	特殊螺栓	SPECIAL BOLT	
4	92040600003	2	六角凸緣螺帽	HEXAGON LOCK NUT	
5	P5681001000	1	置物箱總成	LUGGAGE ASSY	
6	90190601200	4	六角凸緣螺栓	HEXAGON FLANGE BOLT	
7	E9706421000	1	分解工具組合	TOOL PARTS ASSY	
8	NA	1	火星塞套筒	BOX-SPANNER, SPARK PLUG	
13	P5681100000	1	置物箱底蓋	LUGGAGE LOW COVER	
14	90040601400	1	十字槽盤頭機器螺釘	C-R RECESS PAN HD TAPPING SCREW	
15	P6701030000	1	O型環	O-RING	
16	P2681030000	3	襯墊	SPONGE DAMPER	

F10 牌照板。反光片。牌照燈。
 LICENCE PLATE, REFLECTOR,
 LICENCE LAMP .

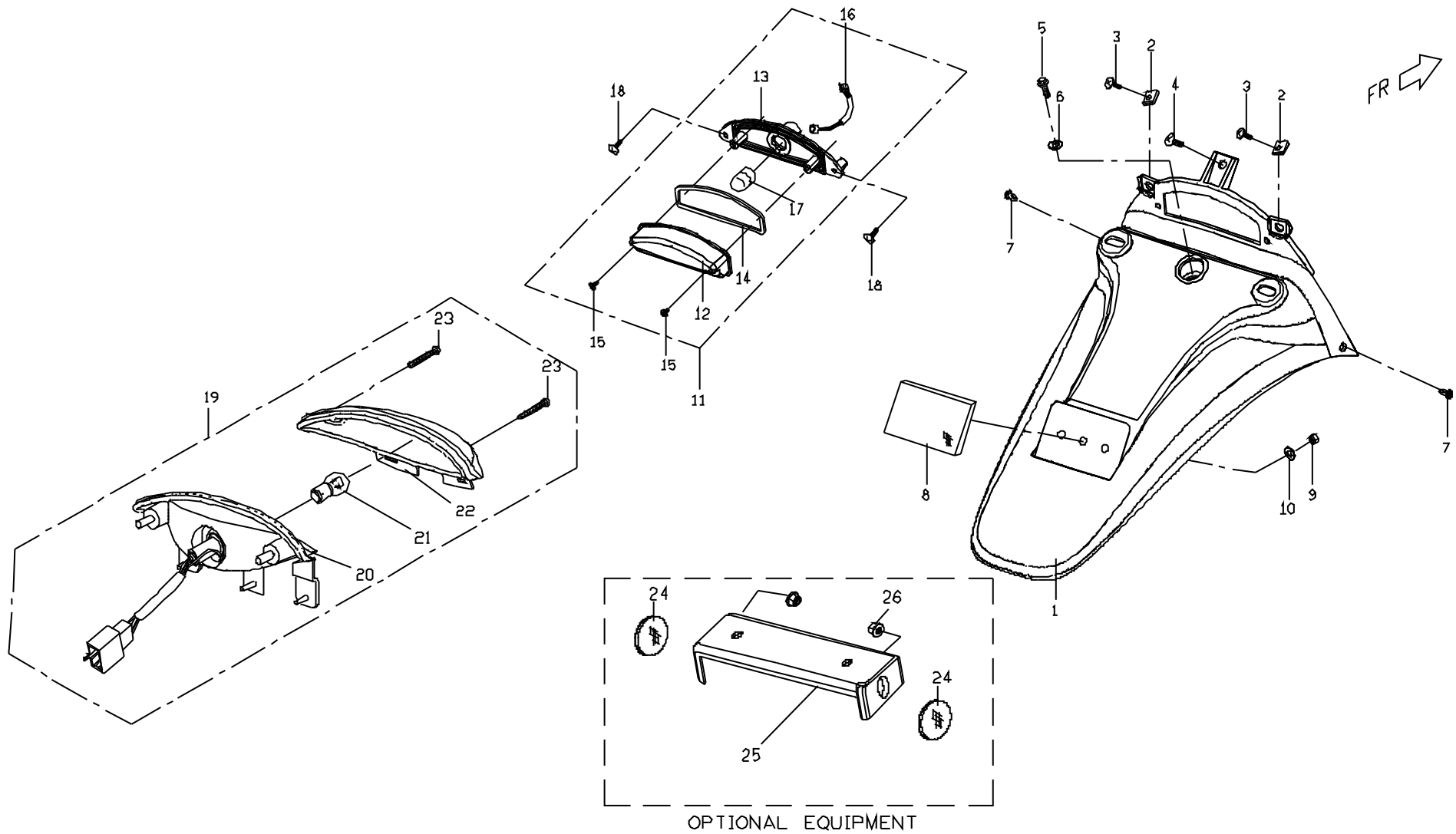

F10. 牌照燈。後燈。 / LICENSE LAMP, REAR LAMP

No.	Part No.	Q' TY	PART NAME	PART NAME	REMARK
項目	零件號碼	數量	零件中文名稱	零件英文名稱	備註
1	P5636003670	1	牌照板	LICENCE PLATE	
2	90150501601	2	自攻螺絲	TAPPING SCREW	
3	92370500003	2	U型彈簧螺帽	SPRING NUT U-TYPE	
4	90130501400	1	自攻螺絲	TAPPING SCREW	
5	90040601400	1	十字槽圓頭自攻螺釘	C-R RECESS PAN HD TAPPING SCREW	
6	92140600005	1	墊圈	WASHER	
7	E1701040000	2	螺旋鉋釘組合	SCRIVET COMP	
8	P5669000000	1	反光片	REFLECTOR	
9	92020500000	1	六角螺帽	HEXAGON NUT	
10	92140500014	1	墊圈	WASHER	
11	P5666900000	1	牌照燈組合	LICENCE LAMP ASSY	
12	P566F910000	1	燈殼	LAMP COVER	
13	P566F920000	1	底座	SOCKET	
14	P566F930000	1	迫緊	PACKING	
15	P566F940000	1	自攻螺絲	TAPPING SCREW	
16	P566F950000	1	電線組	CONNECTING WIRE	
17	P566F960000	1	燈炮	BULB	
18	90110401200	1	自攻螺絲	TAPPING SCREW	
19	P5666000000	1	後燈總成	BACK LAMP ASSY	
20	P566F020000	1	燈座	LAMP SOCKET	
21	98311218050	1	燈泡 (外銷, 12V 18/05W)	LAMP BULB	
22	P566F010000	1	燈罩	LENS	
23	P566F050000	2	十字槽圓頭自攻螺絲	TAPPING SCREW	

F11 車架
FRAME

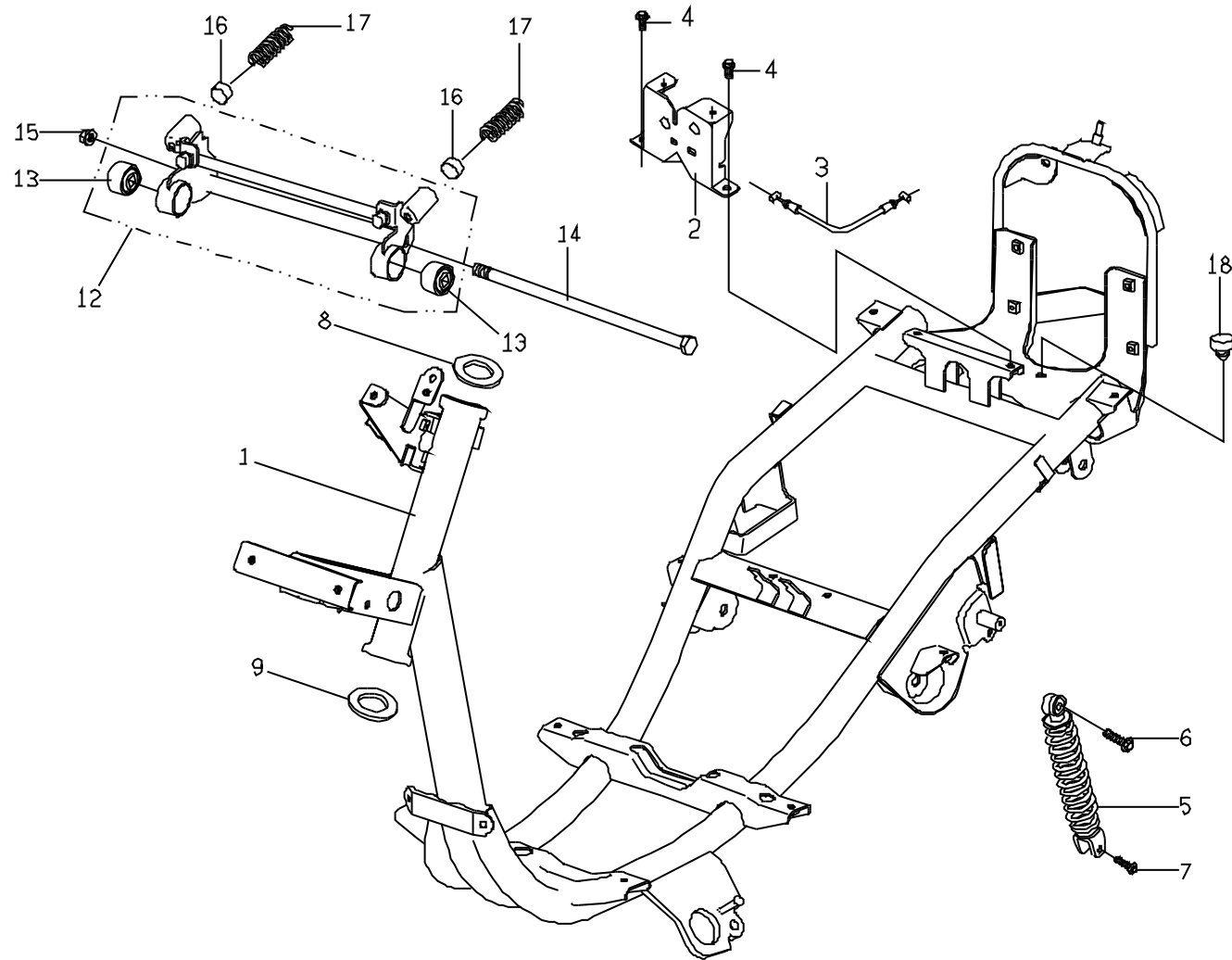

F11. 車架 / FRAME

No.	Part No.	Q' TY	PART NAME	PART NAME	REMARK
項目	零件號碼	數量	零件中文名稱	零件英文名稱	備 註
1	P5421003600	1	車架總成	FRAME COMP	
2	P5671300000	1	座墊鎖座組合	SEAT LOCK COMP	
3	P5671121000	1	座墊鎖拉桿線	SEAT LOCK LEVER CABLE	
4	90190601200	2	六角凸緣螺栓	HEXAGON FLANGE BOLT	
5	P54810000002	1	後緩衝器總成	CUSHION ASSY,RR.	
6	90191004000	1	六角凸緣螺栓	HEXAGON FLANGE BOLT	
7	90190803201	1	六角凸緣螺栓	HEXAGON FLANGE BOLT	
8	P1443020000	1	軸承外座	OUTER BEARING CAGE	
9	P1443020000	1	軸承外座	OUTER BEARING CAGE	
12	P5486000000	1	引擎吊架熔接組合	ENGINE HANGER COMP	
13	E1486010000	2	緩衝襯套	CUSHION RUBBER	
14	90021225000	1	六角頭螺栓	HEXAGON BOLT	
15	92061200001	1	防鬆螺帽	LOCK NUT	
16	E1486040000	2	緩衝膠套	RUBBER,DAMPER	
17	P5486050000	2	壓縮彈簧	SPRING COMPRESSION	
18	P5701010000	1	緩衝橡膠	CUSHION RUBBER	

F12 機油箱

OIL TANK

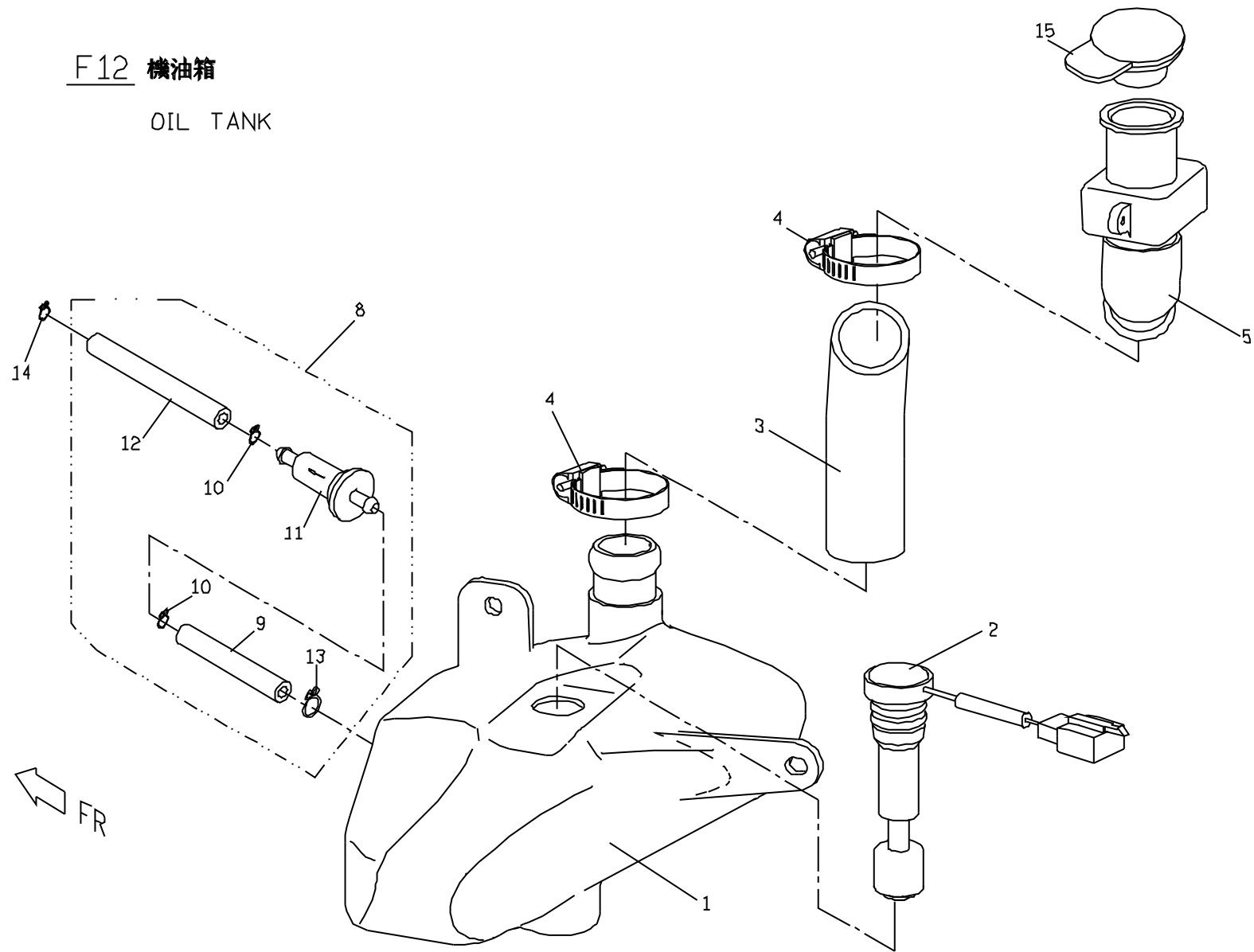

F12. 機油箱 / OIL TANK

No.	Part No.	Q' TY	PART NAME	PART NAME	REMARK
項目	零件號碼	數量	零件中文名稱	零件英文名稱	備註
1	P552250000	1	機油箱	OIL FUEL	
2	P552270000	1	機油量計	OIL GAUSE COMP.	
3	P5522521000	1	機油輸送管	OIL FUEL TRANSMSSION HOSE	
4	P5706270000	2	管束	CLIP	
5	P5522512000	1	機油加油口	OIL FUEL TANK	
8	P5522200000	1	機油濾清器總成	OIL CLEAN ASSY	
9	P552B020000	1	機油輸送管	OIL FUEL TRANSMSSION HOSE	
10	92200700000	2	軟管夾	HOSE CLAMP	
11	E152B000000	1	機油濾清器	OIL CLEAN	
12	P552B010000	1	機油輸送管	OIL FUEL TRANSMSSION HOSE	
13	E1706110000	1	軟管夾	HOSE CLAMP	
14	E1706020000	1	軟管夾	HOSE CLAMP	
15	P1522300000	1	機油箱蓋		

F13. 汽油箱 / FUEL TANK

No.	Part No.	Q'TY	PART NAME	PART NAME	REMARK
項目	零件號碼	數量	零件中文名稱	零件英文名稱	備註
1	P5521010000	1	汽油箱總成	FUEL TANK ASSY	
2	P55215000001	1	汽油箱	FUEL TANK	
3	E1521302000	1	油箱蓋	TANK COVER	
4	P5521700000	1	汽油量計組合	FUEL AGUGE COMP	
5	90180501600	4	六角凸緣螺栓	HEXAGON FLANGE BOLT	
6	90190601601	2	六角凸緣螺栓	HEXAGON FLANGE BOLT	
7	P6523000000	1	自動油杯組合	AUTO COCK	
8	P5421500600	1	油箱支撐板	OIL COVER PLATE	
9	90190601200	4	六角凸緣螺栓	HEXAGON FLANGE BOLT	
10	P75212000001	1	汽油濾清器總成	FUEL FILTER ASSY	
11	P65212100001	1	汽油濾清器組合	FUEL FILTER COMP	
12	P752A0300001	1	汽油管(A)	OIL HOSE	
13	92200700000	2	軟管夾	CLIP	
14	C152A090000	1	止油墊圈	HEXAGON LOCK NUT	
15	P652A0300001	1	汽油管(B)	OIL HOSE	
16	E1706020000	4	軟管夾	CLIP	
17	P5526031000	1	背壓管	HOSE CLAMP	
18	P1706610000	1	壓縮彈簧	SPRING	

F14 主配線
WIRE HARNESS

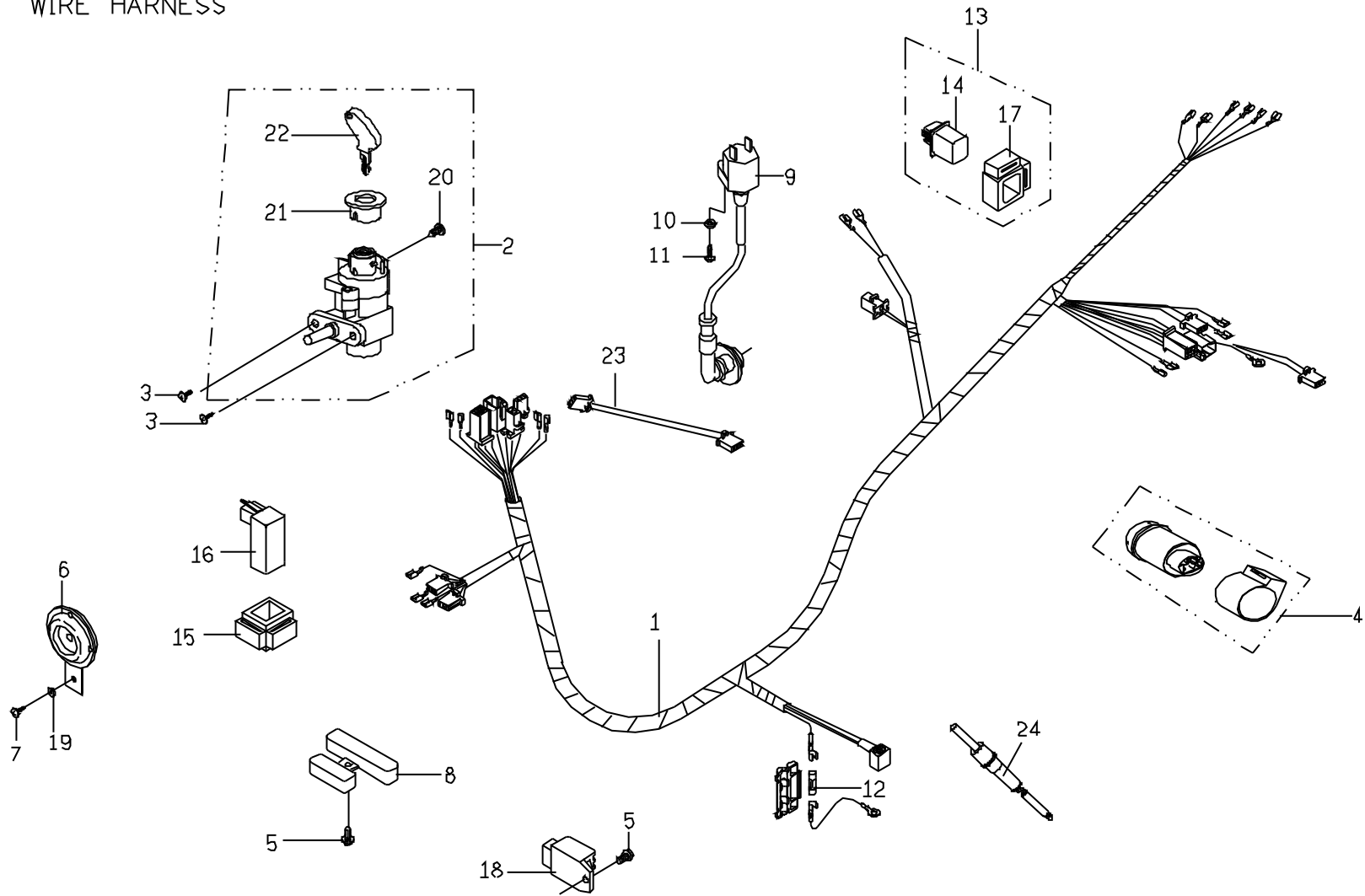

FR.

F14. 電裝零件 / ELECTRIC PARTS

No.	Part No.	Q' TY	PART NAME	PART NAME	REMARK
項目	零件號碼	數量	零件中文名稱	零件英文名稱	備註
1	P5581605000	1	主配線總成	WIRE HARNESS	
2	P5552002000	1	電源鎖總成	IGNITION SWITCH ASSY	
3	90040601601	2	十字槽圓頭機器螺釘	C-R RECESS PAN HD,TAPPING	
4	P2586011000	1	方向繼電器總成	FLASHER RELAY ASSY	
5	90190601200	2	六角凸緣螺栓	HEXAGON FLANGE BOLT	
6	P5583600000	1	喇叭	HORN	
7	90040601400	1	十字槽盤頭機器螺釘	C-R RECESS PAN HD,TAPPING	
8	P15866000002	1	電阻器B	RESISTOR B	
9	P5584600000	1	點火線圈總成	COIL COMP,IGNITION	
10	92110500000	1	彈簧鎖緊墊圈	SPRING WASHER	
11	90070502000	1	十字槽扁圓頭機器螺釘	C-R RECESS PAN HD,TAPPING	
12	E1581630000	1	保險絲	FUSE	
13	P9581000000	1	起動繼電器總成	STARTER RELAY AND SUPPORT COMP	
14	NA	1	起動繼電器	STARTER RELAY ASSY	
15	P1701190000	1	橡膠托架	RUBBER BRACKET	
16	P5582000000	1	電子點火控制器	CDI UNIT COMP	
17	P1701190000	1	橡膠托架	RUBBER BRACKET	
18	C1584000000	1	電壓調整器總成	VOL REGULATOR COMP	
19	92140600005	1	平墊圈	WASHER	
20	90050501200	1	十字槽盤頭機器螺釘	C-R RECESS PAN HD,TAPPING	
21	P555B020000	1	面板	KEY PANEL	
22	ES55B010000	1	鑰匙	DUMMY KEY	
23	P2581660000	1	遠近燈開關短接線	HI/LO CONNECTING COUPLE	FRENCH
23	E1545040000	1	頭燈恆亮截接線	HEADLAMP CONNECTING COUPLE	JAPAN
24	P5581610000	1	側腳柱安全開關	SAFETY SWITCH, SIDE STAND	OPTIONAL PART

F15.貼紙/LANELS

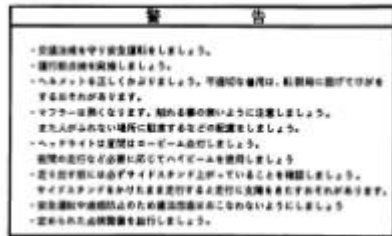

1

C2603001000

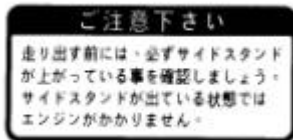

2

C26030500002



3

P1603040000



4

P5601020000



5

P5601030000

MAX. LOAD 3kg

6

P5603020000

F15. 貼紙 / LABELS

No.	Part No.	Q' TY	PART NAME	PART NAME	REMARK
項目	零件號碼	數量	零件中文名稱	零件英文名稱	備 註
1	C2603001000	1	注意事項貼紙(日文)	NOTICE ADHSIVE LABEL	
2	P1603040000	1	汽油使用貼紙	FUEL TYPE LABEL	
3	P5601020000	2	左右車身蓋貼紙	BODY COVER LABEL	
4	P5601030000	1	PGO SCOOTERS貼紙	PGO SCOOTERS LABEL	
5	P5603020000	1	荷重限制貼紙(英文版)	LIMITED LOADING WARNING LABEL	
6	C26030500002	1	側腳安全開關貼紙(日文)	SIDE STAND SAFETY LABEL	